

# MSS, MLD

Installation and operating instructions

GB D DK



## **GB** Declaration of Conformity

We **Grundfos** declare under our sole responsibility that the products **MSS** and **MLD**, to which this declaration relates, are in conformity with the Council Directives on the approximation of the laws of the EC Member States relating to

- Machinery (98/37/EC).  
Standard used: EN ISO 12100.
- Electromagnetic compatibility (89/336/EEC).  
Standards used: EN 61000-6-2 and EN 61000-6-3.
- Electrical equipment designed for use within certain voltage limits (73/23/EEC) [95].  
Standards used: EN 60335-1: 1994, EN 60335-2-41: 1996 and EN 60439-1.
- Construction products (89/106/EEC).  
Standard used: EN 12050-1/-2.

## **D** Konformitätserklärung

Wir **Grundfos** erklären in alleiniger Verantwortung, dass die Produkte **MSS** und **MLD**, auf die sich diese Erklärung bezieht, mit den folgenden Richtlinien des Rates zur Angleichung der Rechtsvorschriften der EG-Mitgliedstaaten übereinstimmen:

- Maschinen (98/37/EG).  
Norm, die verwendet wurde: EN ISO 12100.
- Elektromagnetische Verträglichkeit (89/336/EWG).  
Normen, die verwendet wurden: EN 61000-6-2 und EN 61000-6-3.
- Elektrische Betriebsmittel zur Verwendung innerhalb bestimmter Spannungsgrenzen (73/23/EWG) [95].  
Normen, die verwendet wurden: EN 60335-1: 1994, EN 60335-2-41: 1996 und EN 60439-1.
- Bauprodukte (89/106/EWG).  
Norm, die verwendet wurde: EN 12050-1/-2.

---

## **DK** Overensstemmelseserklæring

Vi **Grundfos** erklærer under ansvar, at produkterne **MSS** og **MLD**, som denne erklæring omhandler, er i overensstemmelse med Rådets direktiver om indbyrdes tilnærmelse til EF medlemsstaternes lovgivning om

- Maskiner (98/37/EF).  
Anvendt standard: EN ISO 12100.
- Elektromagnetisk kompatibilitet (89/336/EØF).  
Anvendte standarder: EN 61000-6-2 og EN 61000-6-3.
- Elektrisk materiel bestemt til anvendelse inden for visse spændingsgrænser (73/23/EØF) [95].  
Anvendte standarder: EN 60335-1: 1994, EN 60335-2-41: 1996 og EN 60439-1.
- Byggevarer (89/106/EØF).  
Anvendt standard: EN 12050-1/-2.

---

Bjerringbro, 1st March 2006

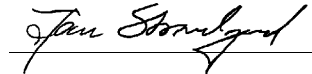

Jan Strandgaard  
Technical Director

# MSS, MLD

**Installation and operating instructions**

4

**GB**

**Montage- und Betriebsanleitung**

27

**D**

**Monterings- og driftsinstruktion**

52

**DK**

# CONTENTS

GB

	Page
<b>1. General description</b>	<b>4</b>
1.1 Applications	5
<b>2. Transportation and storage</b>	<b>5</b>
<b>3. Product description</b>	<b>5</b>
<b>4. Lifting station</b>	<b>5</b>
4.1 Type key, MSS and MLD	5
4.2 Nameplate, MSS and MLD	5
4.3 Collecting tank	6
4.4 Pump	6
4.5 Nameplate, motor	6
4.6 Shaft seal	6
4.7 Motor cable	6
4.8 Level sensor	6
<b>5. Mechanical installation</b>	<b>6</b>
5.1 General description	6
5.2 Mounting of collecting tank	7
5.3 Diaphragm pump	8
<b>6. Controllers LC 109 and LCD 110</b>	<b>8</b>
6.1 Type key, LC 109 and LCD 110 controllers	8
6.2 Nameplate, LCD 110 controller	8
6.3 Accessories	9
6.4 MSS - LC 109	9
6.5 MLD - LCD 110	9
6.6 Tank level above floor	9
6.7 Automatic test run	9
6.8 Functions	9
6.9 Electrical connection	10
6.10 Location and mounting of controller	10
6.11 Wiring diagram	12
<b>7. Start-up</b>	<b>13</b>
7.1 Direction of rotation	13
7.2 DIP switch setting	13
<b>8. LC 109 controller</b>	<b>14</b>
8.1 Control panel	14
8.2 Application	14
8.3 DIP switch	14
8.4 Battery back-up functions	15
8.5 Reset button and ON-OFF-AUTO selector switch	16
8.6 Normal operating conditions	16
8.7 Alarm conditions	17
<b>9. LCD 110 controller</b>	<b>18</b>
9.1 Control panel	18
9.2 Application	18
9.3 DIP switch	18
9.4 Battery back-up functions	19
9.5 Reset button and ON-OFF-AUTO selector switch	20
9.6 Normal operating conditions	20
9.7 Alarm conditions	21
<b>10. Maintenance and service</b>	<b>23</b>
10.1 Electrical maintenance	23
10.2 Cleaning the level sensor	23
10.3 Mechanical maintenance	23
10.4 Contaminated lifting station or components	23
<b>11. Fault finding chart</b>	<b>24</b>
11.1 Fuses	24
<b>12. Technical data</b>	<b>25</b>
12.1 Pump curve	26
<b>13. Disposal</b>	<b>26</b>

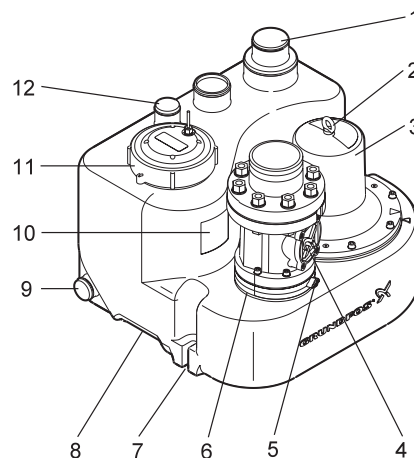

Fig. 1 MSS

TM03 3348 0406

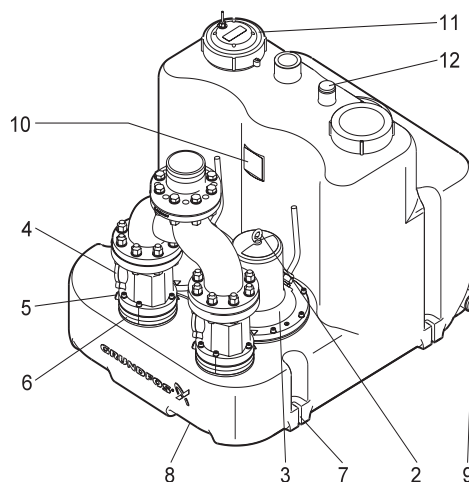

Fig. 2 MLD

TM03 3648 0606

Pos.	Description
1	Vertical inlet
2	Lifting eye
3	Pump
4	Cleaning cover
5	Drain screw for forced opening of non-return valve
6	Non-return valve
7	Fixing points
8	Carrying handle
9	1" port for manually operated diaphragm pump
10	Nameplate
11	Cover with level sensor
12	Vent port



Prior to installation, read these installation and operating instructions. Installation and operation must comply with local regulations and accepted codes of good practice.

## 1. General description

Grundfos MSS and MLD Multilift lifting stations are designed for the collection and pumping of wastewater with no free flow to sewer level. The lifting stations are supplied complete with controller LC 109 or LCD 110.

### 1.1 Applications

Grundfos MSS and MLD Multilift lifting stations are designed for the collection and pumping of:

- wastewater
- sludge-containing water and
- domestic wastewater with discharge from water closets.

The lifting stations are capable of pumping liquids containing fibres, textiles, faeces, etc. This makes them ideal for the collection and pumping of wastewater below sewer level from minor buildings such as private dwellings, blocks of flats, hotels, restaurants, schools, etc.

The Multilift lifting stations are not designed for the pumping of rainwater.

The lifting stations are supplied complete with one or two pumps and a controller.

Lifting station	Controller
MSS, 1-pump lifting station	LC 109
MLD, 2-pump lifting station	LCD 110

### 2. Transportation and storage



The motor lifting eye is only intended for lifting the motor. Never lift or lower the lifting station by means of the lifting eye.

**Note:** The lifting station must be lifted by the carrying handles cast in the bottom of the collecting tank, see pos. 8 in fig. 1 and 2.

For long periods of storage, the pumps and controllers must be protected against moisture and heat.

After a long period of storage, the pumps should be inspected before they are put into operation. Make sure that the impeller can rotate freely.

### 3. Product description

The description of the MSS and MLD Multilift lifting stations is divided into the following sections:

- Section 4. describes the lifting station with collecting tank, pump and level sensor.
- Section 6. describes the controllers LC 109 and LCD 110 as well as the functions of these controllers.

In 5. *Mechanical installation* and the following sections, these components have been described as one unit as required.

### 4. Lifting station

Smell-tight and watertight lifting station complete with one or two pumps. The lifting station includes a collecting tank with all necessary ports for the connection of inlet pipe, discharge pipe, vent pipe and a manually operated diaphragm pump, which is available as an accessory.

The MSS and MLD Multilift lifting stations are supplied complete with single- or three-phase submersible pumps connected to the LC 109 or LCD 110 controller incorporating a pneumatically/electrically operated level switch.

The lifting station MSS has two horizontal inlets in the backside, one horizontal inlet in the side and one vertical inlet in the top. The centre of the horizontal inlet ports is 180 mm and 250 mm, respectively, above floor level. MLD has one vertical inlet for connection to vertical tubes or through a 90° bend to horizontal tubes.

- The vertical inlet port of MSS can be connected to a 100 mm PVC pipe. MLD can be connected to a 150 mm PVC pipe.
- The horizontal inlet port 180 mm above floor level is for connection to Euro-standardized water closets.
- The horizontal inlet port 250 mm above floor level is for connection of wall-mounted water closets.

See 5.1.1 *Installation sketch*.

The lifting station can be connected to a pipework with several water closets. MSS is mainly designed for single-family houses with one or two closets. MLD is designed for commercial use with three or more closets.

### 4.1 Type key, MSS and MLD

Example	M	SS	.22	.3	.4
Lifting station					
SS = one pump					
LD = two pumps					
Output power, P <sub>2</sub> / 100 (W)					
1 = single-phase					
3 = three-phase					
2 = 2-pole motor					
4 = 4-pole motor					

### 4.2 Nameplate, MSS and MLD

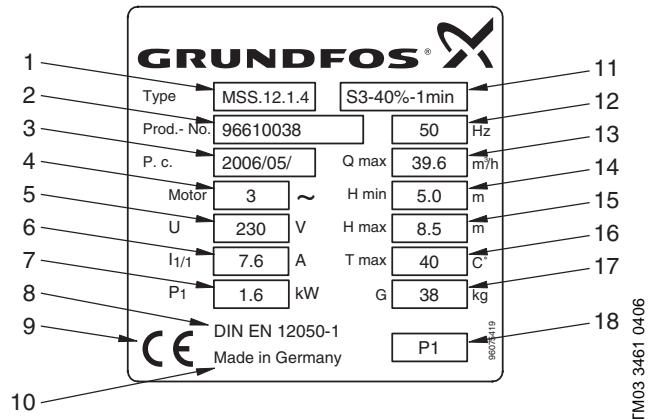

Fig. 3 Nameplate, MSS and MLD

Pos.	Description
1	Type designation
2	Product number
3	Production week and year
4	Number of phases
5	Rated voltage
6	Rated current
7	Input power
8	Approval
9	CE mark
10	Production country
11	Operating mode
12	Frequency
13	Max. flow rate
14	Min. head
15	Max. head
16	Max. liquid temperature
17	Weight
18	Production place

TM03 3461 0406

### 4.3 Collecting tank

The tank volume and effective volume (volume between start and stop) for MSS and MLD Multilift lifting stations appear from the following table:

	MSS	MLD
Inlet level [mm]	180	250
Tank volume [l]	66	270
Effective volume [l]	35	190

MLD Multilift lifting stations have two pumps, thus providing a standby pump in case of pump failure or additional pump performance if the inlet exceeds the performance of one pump. MLD Multilift lifting stations must always be used if the wastewater flow must not be interrupted.

### 4.4 Pump

The pump impeller is designed as a free-flow impeller, which ensures almost unchanged performance throughout the entire life of the pump, see the pump curve in 12.1.

The stator housing of the motor is made of painted aluminium.

**Three-phase pumps:** If the phase sequence is wrong, the controller indicates a fault and prevents the pump(s) from starting. For direction of rotation, see 6.8.1 Control panel and 7.1 Direction of rotation.

### 4.5 Nameplate, motor

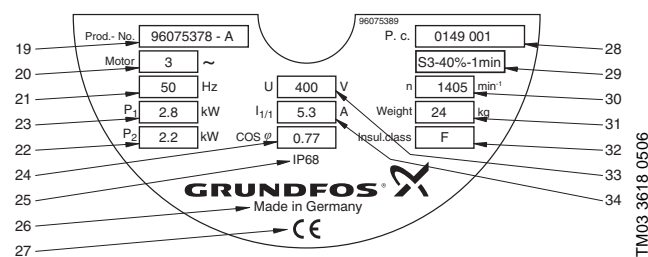

Fig. 4 Nameplate, motor

Pos.	Description
19	Product number and model
20	Number of phases
21	Frequency
22	Input power
23	Shaft power
24	Power factor
25	Enclosure class
26	Production country
27	CE mark
28	Production week and year
29	Operating mode
30	Rated speed
31	Weight
32	Insulation class
33	Rated voltage
34	Rated current

### 4.6 Shaft seal

The shaft seal is lubricated for life and therefore requires no maintenance.

### 4.7 Motor cable

The cable is fitted to the motor part via a cable entry. Enclosure class IP 68.

### 4.8 Level sensor

The level sensor incorporates four pressure sensors. The level sensor also functions as cover at the top of the collecting tank. For selection of inlet level, see 7.2 DIP switch setting.

## 5. Mechanical installation

### 5.1 General description

Before installing the MSS and MLD Multilift lifting stations, ensure that all local regulations covering venting, access to the stations, etc. are observed.



The lifting station must not be covered.

A minimum space of 60 cm around the lifting station is required in order to facilitate installation and service.

Ensure that no back-flow can occur in case of a high water level in the sewage pipe buried in the street outside the building.

Back-flow can be prevented by fitting a goose neck or reversed water seal. The highest point of the goose neck/reversed water seal must be above street level.

The discharge pipe from the pump as well as the discharge pipe from the manually operated diaphragm pump, if any, and the drainage pump, if any, installed below floor level must also be fitted with a goose neck or reversed water seal.

See 5.1.1 Installation sketch.

5.1.1 Installation sketch

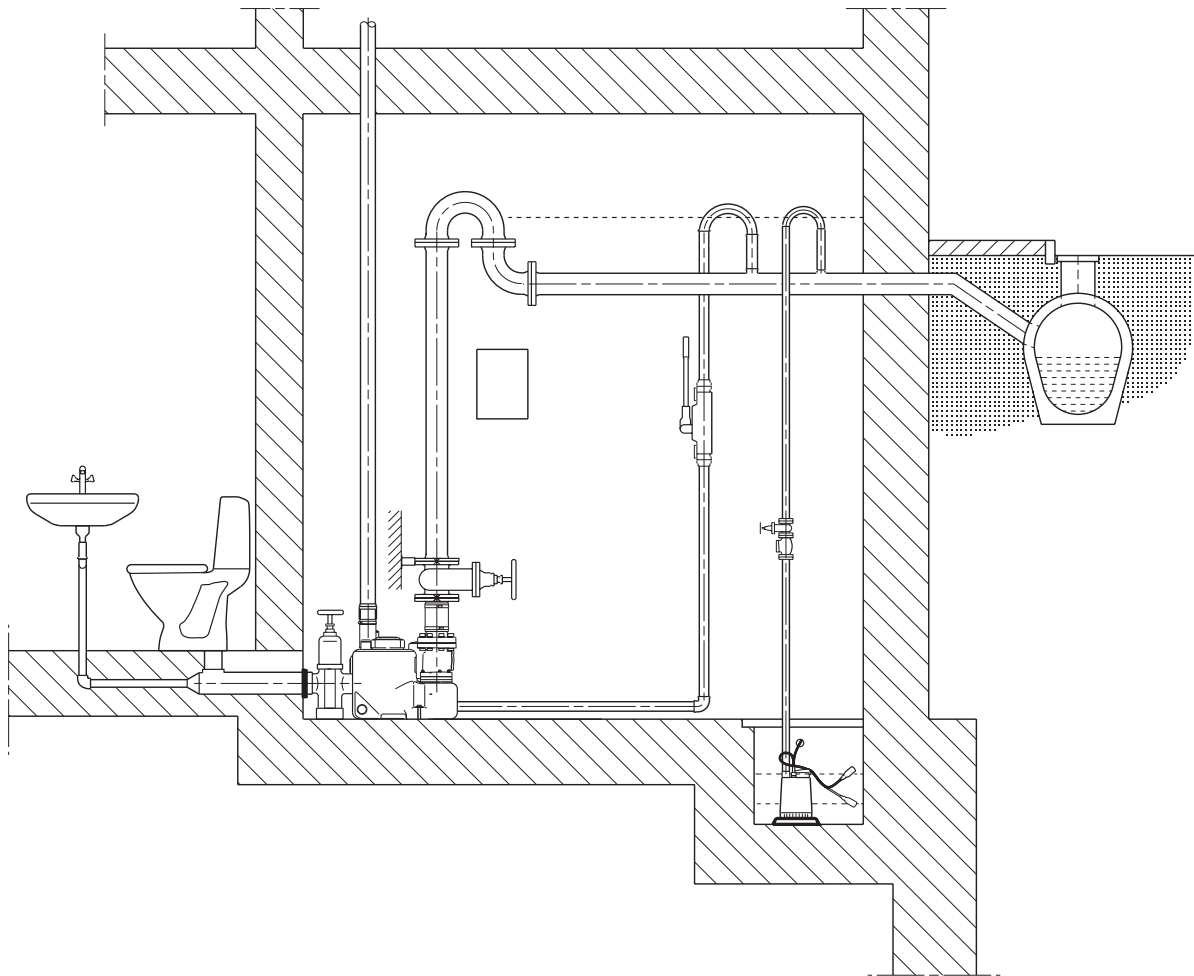

TM03 3462 0406

Fig. 5 Installation sketch

5.2 Mounting of collecting tank

Fasten the collecting tank to an even floor with the dowels, washers and screws supplied with the tank.

To facilitate service, it is advisable to fit isolating valves on the inlet and discharge sides of the tank.

Inlet side: DN 100/DN 150.

Discharge side: DN 80/DN 100.

To avoid sediment build-up in the discharge pipe, the pipe - and the lifting station - should be sized for a flow velocity of minimum 0.7 m/s. For vertical pipes, however, not lower than 1.0 m/s.

For PN 6 PVC pipes, for example, the following flows are required to meet these requirements:

Nominal diameter of pipe	80 mm	100 mm
Flow velocity of 0.7 m/s	14.2 m <sup>3</sup> /h	21.2 m <sup>3</sup> /h
Flow velocity of 1.0 m/s	20.2 m <sup>3</sup> /h	30.3 m <sup>3</sup> /h

The lifting station offers several connections. Drill out (ø127) or cut off the desired connections, see fig. 6, and connect the pipes as required by means of a pipe collar or similar device, see fig. 7. The DN 150 vertical inlet of MLD is predrilled.

**Note:** Push the pipe 60 to 100 mm into the collar.

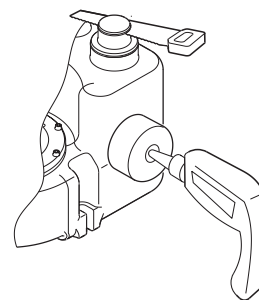

Fig. 6 Cutting and drilling of connections

TM03 3457 0406



When installing the pipes, it must be ensured that the lifting station is not stressed by the pipework.

Flexible connecting pieces supplied:

- 1 connecting piece ø110 (outlet).
- 1 connecting piece ø75 (venting).
- 1 connecting piece ø110 (inlet).

The MLD is provided with a DN 150 inlet gasket.

The MSS is provided with a DN 100 inlet gasket.

Other pipes shown above are for both types.

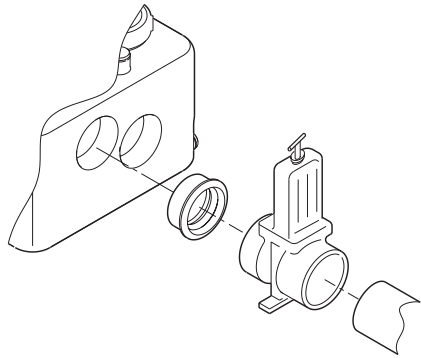

Fig. 7 Installation of isolating valve

TM03 3614 0406

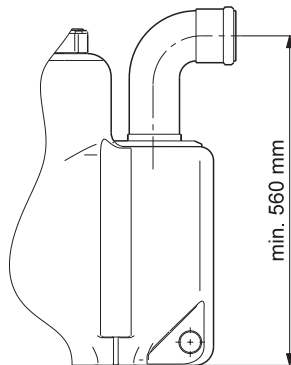

Fig. 8 Minimum inlet height for MLD

TM03 3613 0406

**Note:** The minimum inlet level for MLD is 560 mm, see fig. 8. The lifting stations also have a vertical DN 50 inlet port at the top of the tank for inflow from washbasin, shower, etc. Connect a DN 70 vent pipe to the tank by means of the flexible connection supplied. The vent pipe must be led out into the open air in accordance with local regulations.



Make sure that no weight from the inlet, discharge and vent pipes rests on the tank. Long pipe sections, valves, etc. must be supported.



Never step on the lifting station.

A flexible connection can be ensured if a distance of approx. 5 cm is left between the pipe ends of the inlet, discharge and vent pipes and the ports of the lifting station.

### 5.3 Diaphragm pump

The optional, manually operated diaphragm pump is used for draining the tank in the event of pump failure. The diaphragm pump **must** be fitted with a non-return valve on the discharge side. To facilitate servicing of the diaphragm pump, it is advisable to fit a 1" isolating valve to the tank port.

#### 5.3.1 Blanking flange

If a pump has to be removed for service, the tank can be provided with a blanking flange in order to close it hermetically. The blanking flange is available as an accessory. Fitted to MLD Multilift lifting stations, the blanking flange also allows continued operation by means of the remaining pump.

#### 5.3.2 Drainage pump

If an MSS or MLD Multilift lifting station is installed in a cellar with the risk of penetrating groundwater, it is advisable (in certain countries required) to install a drainage pump in a separate pump sump below floor level. The installation sketch in 5.1.1 shows a lifting station installed in accordance with the regulations in force for this type of lifting station.

**Note:** The collecting tank, pumps and cables may be flooded by the pumped liquid for short levels. The controller must be installed in a dry and well ventilated place.

## 6. Controllers LC 109 and LCD 110

The LC 109 and LCD 110 controllers are designed for the control of MSS and MLD Multilift lifting stations.

The controllers incorporate the necessary components such as contactors, control board with indicator lights for indication of operating condition as well as a level input which, via a cable, is activated directly by the sensors in the collecting tank.

The controller functions are described in 6.8 Functions.

The controller type, voltage variant, etc., appear from the type designation on the nameplate placed on the side of the controller cabinet.

The LC 109 and LCD 110 controllers are designed for direct-on-line starting (DOL).

### 6.1 Type key, LC 109 and LCD 110 controllers

Example	LC	109	.230	.1	.7	.35
LC = 1-pump controller LCD = 2-pump controller						
109 = type designation						
Supply voltage [V]						
1 = single-phase 3 = three-phase						
Maximum operating current per pump [A]						
Run capacitor: 35 = 35 µF 50 = 50 µF						

### 6.2 Nameplate, LCD 110 controller

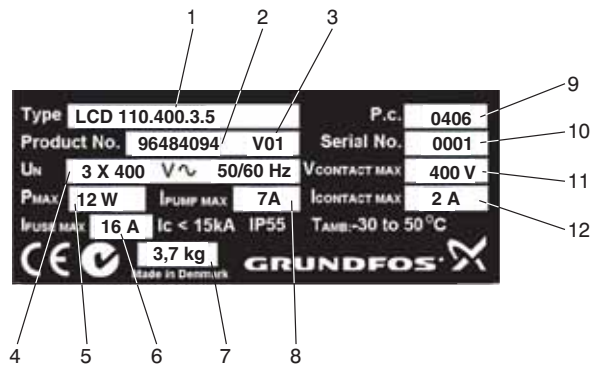

Fig. 9 Nameplate, LCD 110 controller

TM02 8525 0304

Pos.	Description
1	Type designation
2	Product number
3	Version number
4	Rated voltage
5	Power consumption
6	Maximum back-up fuse
7	Weight
8	Maximum pump input current
9	Production year and week
10	Serial number
11	Maximum voltage at contactor
12	Maximum current at contactor

## 6.3 Accessories

Accessories for the controllers are described in the following sections.

### 6.3.1 Accumulator

An accumulator maintaining the alarm signal in case of supply failure is available as an accessory. Fitted inside the controller via a plug, the accumulator ensures that an alarm can be given within 9 hours after the electricity supply has been switched off.

The accumulator is partly charged on delivery. It will be fully charged after 24 hours under voltage. After discharge, the charging time is approx. 24 hours. The accumulator is automatically charged when the electricity supply is switched on.

**Note:** Used-up NiMH accumulators must be disposed of in accordance with local regulations.

### 6.3.2 Hour and start counters

Hour and/or start counters are available as accessories. They are also available as a combined unit.

## 6.4 MSS - LC 109

- When the liquid level in the collecting tank reaches the pump starting level, the pump will start.
- After the stop signal has been given, the pump will run for approx. 8 seconds (stop delay). The stop delay is adapted to the tank capacity and the pump type. The factory settings should only be changed if the tank is not sufficiently drained in the application in question or if water hammering appears. For example, if a high head is required, the tank cannot be sufficiently drained during the stop delay, see "Switch 5, 6 and 7" in *7.2 DIP switch setting*.
- If the liquid level rises to alarm level, the pump will start and an alarm is given until the liquid level is below alarm level. Then the alarm indication is automatically reset by the controller. If required, manual resetting of the alarm indication can be selected, see "Switch 9" in *7.2 DIP switch setting*.

## 6.5 MLD - LCD 110

The 2-pump controller ensures alternating operation of the pumps.

- When the liquid level in the collecting tank reaches the pump starting level, the first pump will start.
- If the liquid level rises further to the next starting level, the second pump will start.
- A further rise in the liquid level after both pumps have started will cause an alarm until the liquid level is below alarm level.
- After the stop signal has been given, the second pump will run for approx. 15 seconds (stop delay). The stop delay is adapted to the tank capacity and the pump type. The factory settings should only be changed if the tank is not sufficiently drained in the application in question or if water hammering appears. For example, if a high head is required, the tank cannot be sufficiently drained during the stop delay, see "Switch 5, 6 and 7" in *7.2 DIP switch setting*.
- After the stop signal has been given, the first pump will run for approx. 13 seconds (stop delay).
- When the pump starting level is reached again, an automatic pump changeover will take place (alternating operation).
- If the liquid level rises to alarm level, both pumps will start.
- Different stop times ensure an even load on the mains supply and thus water hammer is prevented.

## 6.6 Tank level above floor

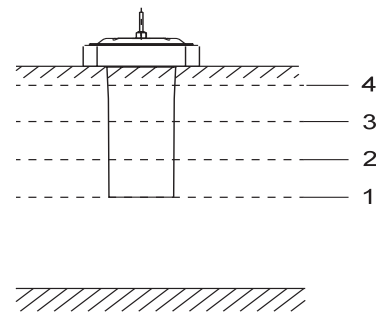

Fig. 10 Tank levels

MSS, 1-pump lifting station			
Level	Height above floor [mm]	Inlet level 180 mm	Inlet level 250 mm
4	350	High-level alarm	High-level alarm
3	300	–	–
2	250	–	Start
1	180	Start	–
MLD, 2-pump lifting station			
Level	Height above floor [mm]	Inlet level min. 560 mm	
4	560	High-level alarm	
3	510	Start - pump 2	
2	460	Start - pump 1	
1	81	Stop	

## 6.7 Automatic test run

The controller is factory-set to "automatic test run", switch 4 in position ON. When the function is active, a test run of 2 seconds will be carried out if the pump/pumps have not been running for 24 hours.

The function can be deselected, see "Switch 4" in *7.2 DIP switch setting*.

## 6.8 Functions



Before making any work on lifting stations, etc., it must be ensured that the electricity supply has been switched off and that it cannot be accidentally switched on.

The functions of the LC 109 and LCD 110 controllers are described in the following sections.

### 6.8.1 Control panel

The LC 109 1-pump controller has a CU 211 module.

The LCD 110 2-pump controller has a CU 214 module.

## 6.9 Electrical connection

The electrical connection must be carried out in accordance with local regulations.



Before making any connections in the LC 109 or LCD 110 or work on lifting stations, etc., it must be ensured that the electricity supply has been switched off and that it cannot be accidentally switched on.

The cable length between motor and controller is 4 metres. The controller can be placed within the length of the cable.

The supply cable for the controller is approx. 1.5 metres.

The controller connected to the pump is to be mounted on a wall in accordance with local regulations and 6.10 *Location and mounting of controller*.

The operating voltage and frequency are marked on the pump and controller nameplates. The voltage tolerance must be within  $-10\%/+6\%$  of the rated voltage. Make sure that the lifting station is suitable for the voltage and frequency available at the installation site.

**Three-phase connection:** Make sure that the phase sequence is correct, see pos. 3 in 6.8.1 *Control panel*.

All cables/wires must be fitted through the cable entries and gaskets (IP 55).

Maximum back-up fuse is stated on the controller nameplate and in the table in 12. *Technical data*.

If required according to local regulations, an external mains switch must be installed.

Pump motors for MSS and MLD Multilift lifting stations have a thermal switch incorporated in the motor windings. Via the controller, the thermal switch disconnects the electricity supply to the pump in case of excessive winding temperature.

The motor-protective circuit breaker, if installed, must be set to the rated motor current, see pump nameplate.

**Controllers for single-phase pumps** also incorporate the necessary run capacitors.

Pump type	Run capacitor	
	[ $\mu$ F]	[VAC]
1.2 kW	35	400
1.5 kW	50	400

The lifting stations require no further motor protection.

The electrical connection must be carried out in accordance with the marking on the supply cable to the controller.

- Single-phase lifting stations have a Schuko plug.  
**Note:** In countries, where the Schuko plug is not used as standard, this plug **must** be replaced according to local regulations.
- Three-phase lifting stations have a CEE plug.

If the cables between pump and controller as well as the supply cable have been disconnected, the electrical connection must be carried out as shown in the wiring diagram, section 6.11.

An external fault indication device can be connected to one of the two potential-free fault signal outputs (NO contacts) of the controller. Maximum load: 250 VAC, 5 A, AC1.

## 6.10 Location and mounting of controller

The controller must be installed in a dry and well ventilated place.

When installed outdoors, the LC 109 and LCD 110 controllers must be placed in a protective shed or cupboard.

The LC 109 and LCD 110 must not be exposed to direct sunlight.

Before mounting the controller, remove the transport protectors, if any, from inside the cabinet.

Mount the LC 109 and LCD 110

- on a plane wall surface
- with the cable entries pointing downwards (additional cable entries, if required, must be fitted in the bottom plate of the cabinet)

- with four screws through the mounting holes in the back plate of the cabinet, see fig. 11. The mounting holes must be bored with a 4 mm bore. Fit the screws into the mounting holes and tighten securely. Fit the plastic caps supplied with the controller on the screws (IP 55).

Fig. 11 shows the dimensions of the controller cabinet for wall-mounting.

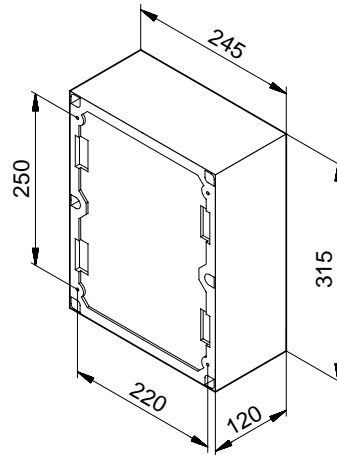
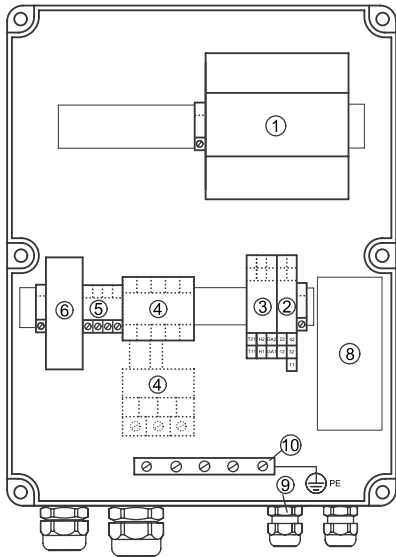

Fig. 11 Controller cabinet for wall mounting

Fig. 12 shows the *internal* construction of the LC 109.



TM02 2347 4701

**Fig. 12** Internal construction of LC 109

Fig. 13 shows the terminals listed under positions 2 and 3.

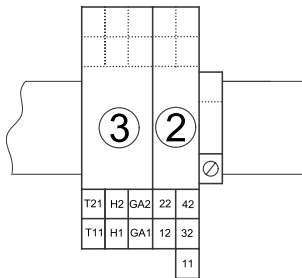

TM02 2348 4101

**Fig. 13** Terminals

**6.10.1 Key to the symbols in figs. 12 and 13**

Pos.	Description
1	Module CU 211
2	Terminal block for level inputs (11-12, 22, 32, 42)
3	Terminal block with: input for the motor thermal switch (T11-T21) output for external alarm device for high-level alarm (H1-H2) output for external alarm device for common alarm (GA1-GA2).
4	Motor-protective circuit breaker (only if a motor-protective circuit breaker has been installed).
5	Terminal block for electricity supply (a three-phase variant is illustrated above).
6	Fuse holders for control circuit fuses (1 to 3 depending on voltage/current variant).
8	Run capacitor (single-phase pumps only).
9	Cable entries
10	Earth bar (⊕PE)

Fig. 14 shows the *internal* construction of the LCD 110.

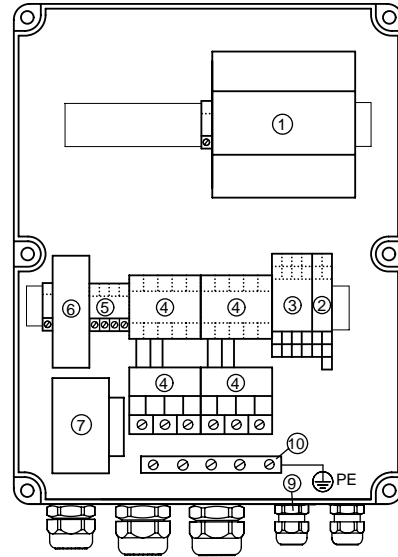

TM02 4926 1802

**Fig. 14** Internal construction of LCD 110

Fig. 15 shows the terminals listed under positions 2 and 3.

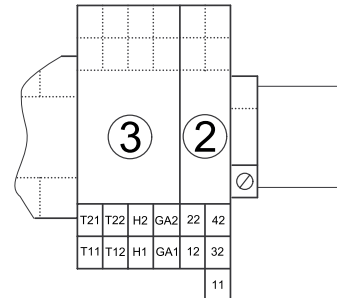

TM02 2349 4101

**Fig. 15** Terminals

**6.10.2 Key to the symbols in figs. 14 and 15**

Pos.	Description
1	Module CU 214
2	Terminal block for level inputs (11-12, 22, 32, 42).
3	Terminal block with: inputs for the motor thermal switches (T11-T21, T12-T22) output for external alarm device for high-level alarm (H1-H2) output for external alarm device for common alarm (GA1-GA2).
4	Motor-protective circuit breakers, pumps 1 and 2 (only if motor-protective circuit breakers have been installed).
5	Terminal block for electricity supply (a three-phase variant is illustrated above).
6	Fuse holders for control circuit fuses (1 to 3 depending on voltage/current variant).
7	Isolating transformer
8	Run capacitor (single-phase pumps only)
9	Cable entries
10	Earth bar (⊕PE)

## 6.11 Wiring diagram

GB

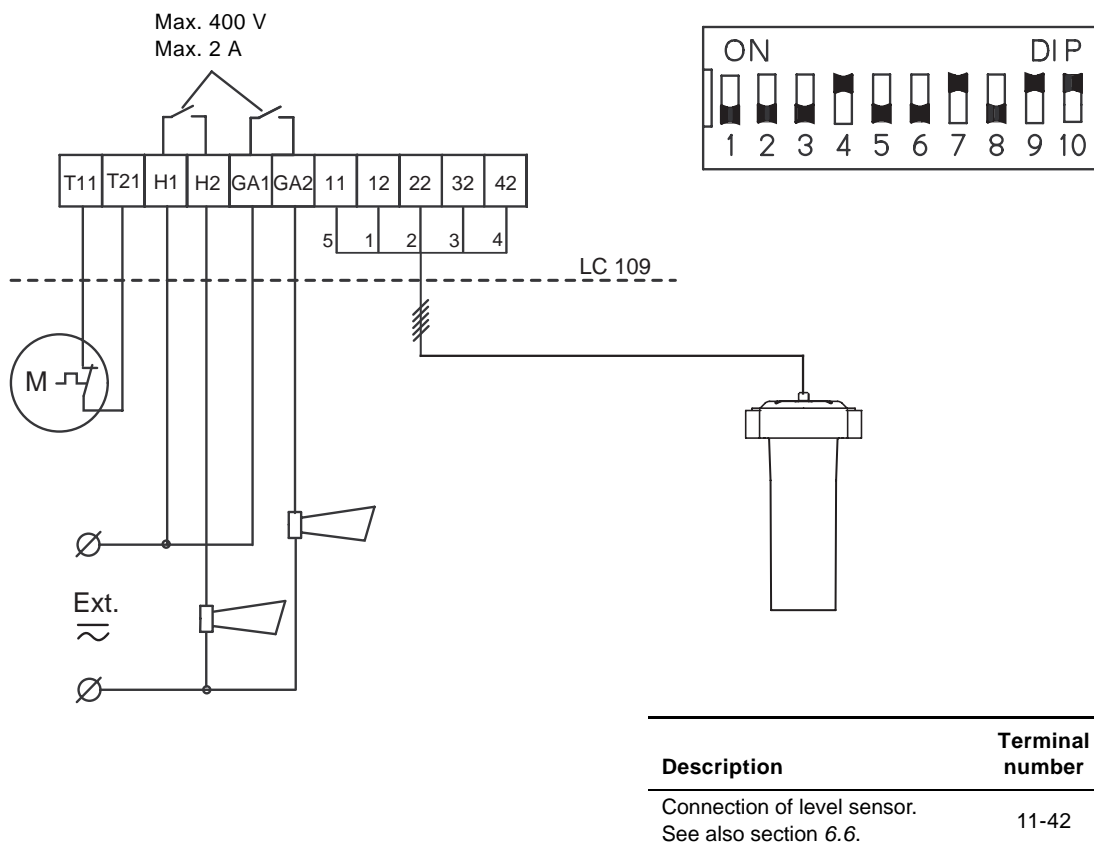

Fig. 16 Wiring diagram, MSS

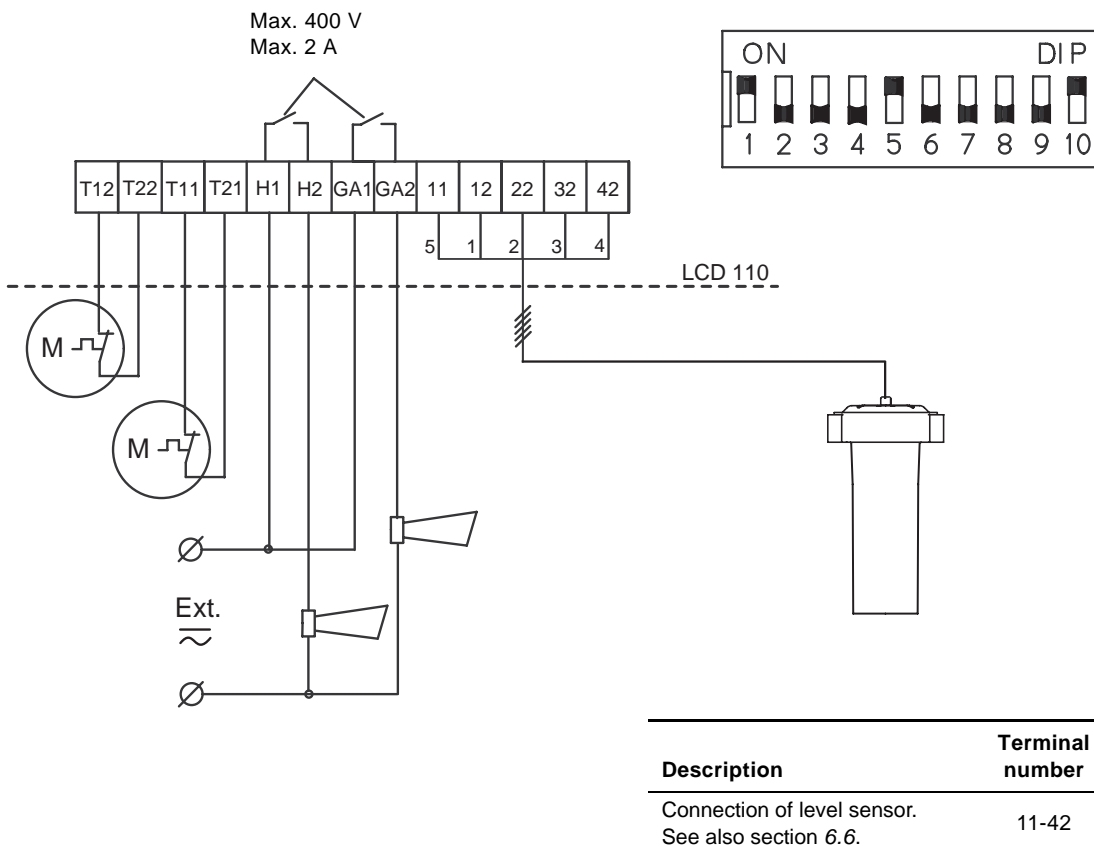

Fig. 17 Wiring diagram, MLD

TM03 3463 0406

TM03 3464 0406

## Single-phase connection

### with motor-protective circuit breaker

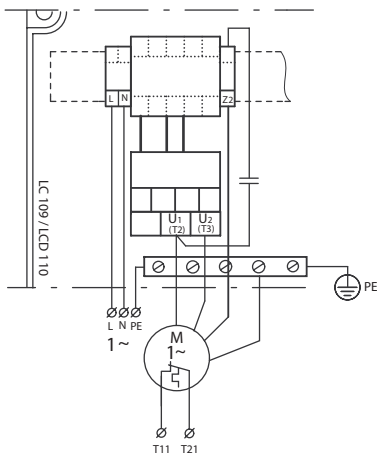

TM03 3465 0406

### without motor-protective circuit breaker

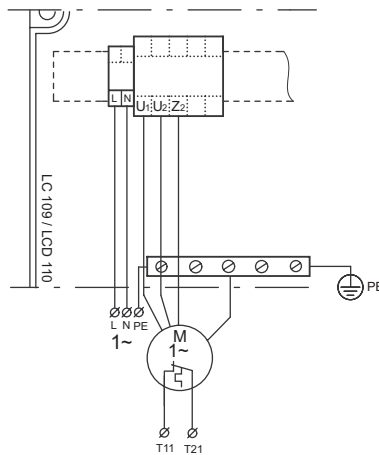

## Three-phase connection with/without motor-protective circuit breaker

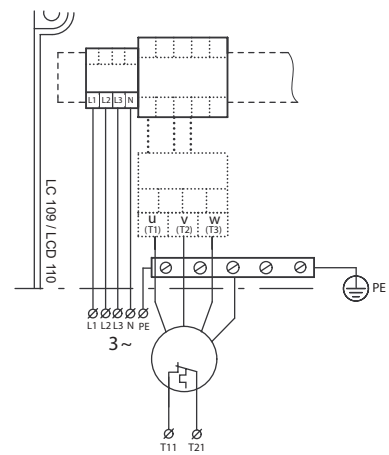

TM03 3470 0406

TM03 3471 0406

Fig. 18 Wiring diagrams

## 7. Start-up

When the Multilift lifting station has been installed correctly and connected in accordance with local regulations and the controller settings have been made, the lifting station can be started up.



Before starting any work on pumps used for pumping liquids which might be hazardous to health, thorough cleaning/venting of pumps, tank, etc. must be carried out according to local regulations.

Before making any connections in the LC 109 or LCD 110 or work on lifting stations, etc., it must be ensured that the electricity supply has been switched off and that it cannot be accidentally switched on.

Start-up must be carried out by authorized personnel.

Proceed as follows:

1. If, during installation of the lifting station, it has been necessary to disconnect the LC 109 or LCD 110 from the station, make sure that the terminals are connected as before the disconnection.  
See also 6.11 *Wiring diagram*.
2. If a motor-protective circuit breaker has been installed, check that the settings are correct.
3. **MSS:** Check that the correct inlet level, 180 or 250 mm, has been selected, see "Switch 1" in 7.2 *DIP switch setting*.
4. Switch on the electricity supply.  
**Three-phase lifting stations only:** If a wrong phase sequence is indicated on the controller control panel, interchange two phases in the CEE plug.
5. Open all isolating valves.
6. Test-run the pump for **maximum 1 minute** by pushing the ON-OFF-AUTO selector switch into position ON ( I ), see section 8.5.
7. Push the ON-OFF-AUTO selector switch into position AUTO ( O ), see section 8.5.
8. Supply liquid (clean water) to the tank until the pump starts. Stop the liquid supply and check that the tank is empty/the liquid level has fallen to stop level.

If high heads are required, the stop delay can be changed, see 7.2 *DIP switch setting*.

**Note:** The drain screw on the side of the non-return valve is used for emptying the discharge pipe between the non-return valve and the isolating valve, if fitted.

During normal operation, the screw must be left untightened. When the drain screw is tightened, see fig. 19, the non-return valve will be forced open and the contents of the discharge pipe will be emptied into the collecting tank.

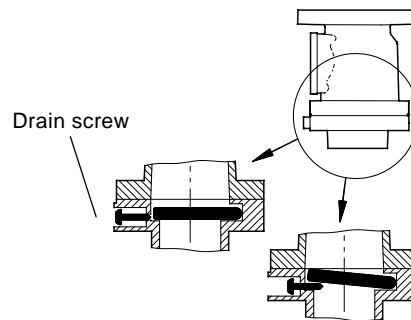

Fig. 19 Drain screw

### 7.1 Direction of rotation

When the lifting station is delivered from factory, the direction of rotation of the pumps is correct.

**Three-phase lifting stations only:** If the cables between controller and pumps have been disconnected, point 1 in 7. *Start-up* must be observed.

If a wrong phase sequence is indicated on the controller control panel, interchange two phases in the CEE plug.

### 7.2 DIP switch setting

In the controllers LC 109 and LCD 110, the modules CU 211 and CU 214 have a 10-pole DIP switch in the bottom right corner, see fig. 21.

**Note:** During setting, the controller must be off circuit for at least 1 minute to ensure the correct configuration during start-up after change of the DIP switch setting.

The DIP switch setting offers the following possibilities:

- setting of inlet level (switch 1)
- deselection of starting delay and automatic test run (switch 4)
- setting of stop delay (switches 5, 6 and 7)
- selection of automatic alarm resetting (switch 9)
- selection of automatic restarting (switch 10).

See explanations of the settings below.

Fig. 22 shows the factory setting of the DIP switch.

TM02 2352 4101

## 8. LC 109 controller

### 8.1 Control panel

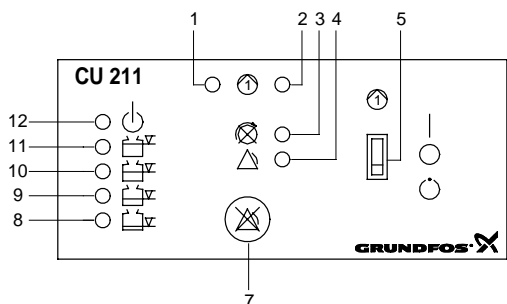

TM01 6425 3902

Fig. 20 Control panel, CU 211 module

#### Key to the symbols in fig. 20

Pos.	Description
1	Green indicator light, indicating starting delay (flashing) and pump operation (permanently on).
2	Red indicator light, indicating pump fault, flashing or permanently on, see section 8.7.
3	Red indicator light, indicating wrong phase sequence (three-phase pumps only).
4	Red indicator light, indicating common alarm.
5	ON-OFF-AUTO selector switch, three positions, see section 8.5.
7	Reset button, push-button for manual resetting of alarm signals to external alarm devices and the built-in buzzer, see section 8.5.
8, 9, 10 and 11	Four orange indicator lights, which are activated by the pressure sensors in the tank. In case of high-level alarm, the top indicator light is flashing and the three other indicator lights are permanently on.
12	Green indicator light, indicating that the electricity supply has been switched on.

### 8.2 Application

The LC 109 enables:

- control of one pump based on signals from the level sensor in the tank
- deselection of automatic test run during long periods of inactivity (every 24 hours)
- battery back-up in case of mains supply failure
- starting delay within the range from 0 to 255 sec. (random) after returning from battery operation to mains operation (resulting in an even mains load when several lifting stations are started up at the same time; only in the case of battery operation)
- selection of automatic alarm resetting
- selection of automatic restarting
- setting of stop delays matching the current operating conditions
- indication of liquid level
- alarm indication of:
  - inadmissibly high liquid level, which triggers a high-level alarm
  - too high motor temperature (temperature sensor)
  - wrong phase sequence 1
  - mains supply failure
  - defective level sensor.
- As standard, the LC 109 controller have two alarm outputs (NO contacts) for:
  - common alarm and
  - separate high-level alarm.

Common alarm and high-level alarm are signalled acoustically via a built-in buzzer.

### 8.3 DIP switch

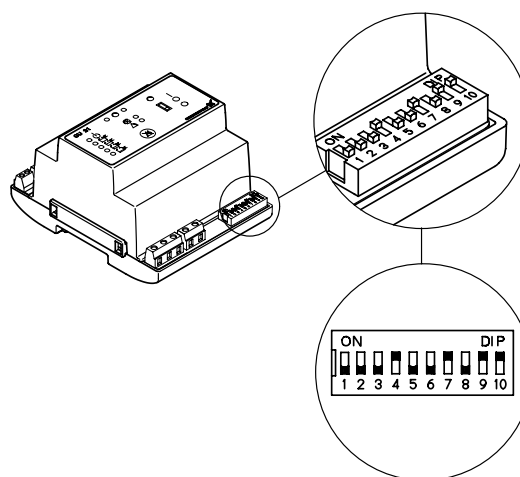

TM02 2483 3802

Fig. 21 CU 211 module with DIP switch

#### 8.3.1 Factory-setting of DIP switch

The DIP switch is factory-set, as shown in fig. 22.



TM03 3654 0606

Fig. 22 Factory setting of DIP switch

Each individual switch (1 to 10) of the DIP switch can be set to position OFF or ON.

**Note:** The DIP switch *must not* be set to other switch combinations than those described in this section.

Set the switches 1 to 10 as follows:

- Switch 1, inlet level:

When the DIP switch setting is changed, the controller must be switched off for at least 1 minute!

	This setting determines the inlet level of the lifting station. OFF corresponds to a 180 mm inlet level and ON corresponds to a 250 mm inlet level.
--	---

- Switches 2 and 3:

When the DIP switch setting is changed, the controller must be switched off for at least 1 minute!

	Switches 2 and 3 have no function in connection with the application, but this setting <i>must</i> be maintained.
--	---

- Switch 4, starting delay and automatic test run (only in connection with battery backup):

When the DIP switch setting is changed, the controller must be switched off for at least 1 minute!

	At this setting, the start-up is delayed within the range from 0 to 255 sec. (random) after the electricity supply has been switched on <i>when</i> the liquid level is sufficiently high. Automatic test run every 24 hours.
--	---

	After the electricity has been switched on, the pump will start immediately <i>when</i> the liquid level is sufficiently high. No automatic test run.
--	---

- Switch **5, 6** and **7**, stop delay:

When the DIP switch setting is changed, the controller must be switched off for at least 1 minute!

The **stop delay** is the time from the stop signal is given until the pump is stopped.  
The stop delay is adapted to the tank capacity and the pump type.  
The setting should only be changed if the tank is not sufficiently emptied in the application in question.

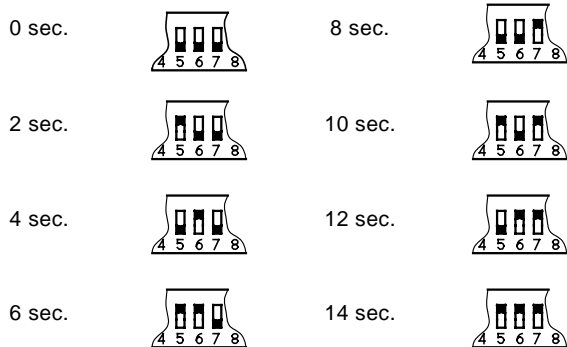

- Switch **8**:

When the DIP switch setting is changed, the controller must be switched off for at least 1 minute!



Switch 8 has no function in connection with the application, but this setting *must* be maintained!

- Switch **9**, automatic alarm resetting:

When the DIP switch setting is changed, the controller must be switched off for at least 1 minute!



This setting ensures automatic resetting of alarm signals to external alarm devices and the built-in buzzer. However, an alarm signal will only be reset if the cause of the fault no longer exists.



At this setting, the alarm signal must be reset manually by means of the reset button (the reset button is described in 8.5 Reset button and ON-OFF-AUTO selector switch).

- Switch **10**, automatic restarting:

When the DIP switch setting is changed, the controller must be switched off for at least 1 minute!



This setting must not be changed. It ensures automatic restarting of the motor after it has been cut out on account of too high temperature.

### 8.4 Battery back-up functions

If a back-up battery for module CU 211 is installed, the following functions will be carried out if the normal electricity supply to the LC 109 fails (see also the illustrations below):

- The common alarm is active, the **red** indicator light is on – *cannot* be reset!
- If the *external* alarm device for common alarm is supplied from an external power source, this device will be active – *cannot* be reset by means of the reset button!
- The built-in buzzer is activated – can be reset by means of the reset button!
- If the liquid level rises above the level for high-level alarm, the top **orange** indicator light will be **flashing** and the second **orange** indicator light from the top will be permanently on.
- If the starting delay function and automatic test run were selected (switch 4 of the DIP switch) (factory setting), the start-up will be delayed after the electricity supply has been switched on when the liquid level is sufficiently high, see 7.2 DIP switch setting.

The table below shows the situations which may occur if the normal electricity supply to the LC 109 fails and a back-up battery is connected:

- = the indicator light is off.
- ⊗ = the indicator light is on.
- ⊛ = the indicator light is flashing.

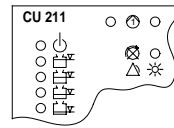

Mains supply failure:

- The common alarm is active. The **red** indicator light is on.
- The green indicator light (electricity supply switched on) is *off*.

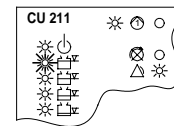

Mains supply failure *and* high-level alarm:

- The common alarm is active. The **red** indicator light is on.
- The top **orange** indicator light is **flashing**.
- The three other **orange** indicator lights are on.
- The green indicator light (electricity supply switched on) is *off*.

## 8.5 Reset button and ON-OFF-AUTO selector switch

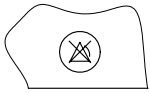

The **reset button** is a push-button for manual resetting of alarm signals to *external* alarm devices and the built-in buzzer (i.e. *not* for resetting of the alarm memory as this is reset by means of the ON-OFF-AUTO selector switch, see position OFF (○)).

Even if the fault condition still exists, the *external* alarm devices and the built-in buzzer will be reset when the reset button is pressed.

The **ON-OFF-AUTO selector switch** has three different positions:

**ON (|)**, top position:

- The pump will start when the selector switch is pushed into this position (unless a motor-protective circuit breaker, if any, has cut out the pump).
- If the thermal switch of the motor registers overtemperature, the pump will *not* be switched off.

**Note:** It is the user's responsibility to decide how long the pump is to run with this fault indication. Over a long period, the pump will be damaged!

**OFF (○)**, middle position:

- The pump *cannot* start when the selector switch has been set to this position.
- The alarm memory is reset by pushing the selector switch into position OFF (○). The alarm memory is the light indication of a fault condition which has disappeared. If a fault condition still exists when the selector switch is pushed into position ON (|) or AUTO (○), the alarm indication will be repeated immediately.

**AUTO (○)**, bottom position:

- The pump is controlled by the input signals from the level sensor and the pump(s) according to the selected DIP switch setting.
- Alarm signals will automatically be reset. Switch 9 of the DIP switch can, however, be set to manual resetting which is carried out by means of the reset button, see 7.2 *DIP switch setting*.
- The pump will restart automatically when a given fault condition disappears.
- When the pump starts automatically after a fault condition which has disappeared, the indicator light will continue to show the fault condition (alarm memory) and the indication can only be removed by resetting the alarm memory, see position OFF (○).

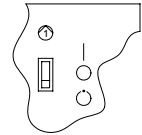

## 8.6 Normal operating conditions

○ = the indicator light is off.

\* = the indicator light is on.

\* = the indicator light is flashing.

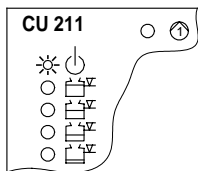

The liquid level in the collecting tank is *lower than* the starting level of the pump:

- Electricity supply switched on. The **green** indicator light is on.

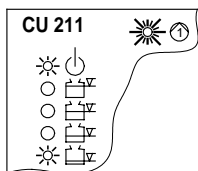

The liquid level in the collecting tank is *higher than* the starting level of the pump:

- Starting delay of the pump (this only applies to starting after interruption of electricity supply and if a back-up battery has been fitted). The **green** indicator light is **flashing**.
- The bottom **orange** indicator light is on.
- Electricity supply switched on. The **green** indicator light is on.

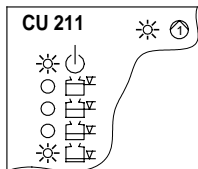

The liquid level in the collecting tank is *higher than* the starting level of the pump:

- The pump is running. The **green** indicator light is **on**.
- The bottom **orange** indicator light is on.
- Electricity supply switched on. The **green** indicator light is on.

### 8.7 Alarm conditions

**Common alarm** activates:

- red indicator light
- built-in buzzer and
- *external* alarm device for common alarm.

**High-level alarm** activates:

common alarm (see above),

*external* alarm device for high-level alarm

- the top orange indicator light (flashing) and
- the other orange indicator lights (permanently on).

○ = the indicator light is off.

※ = the indicator light is on.

⊛ = the indicator light is flashing.

The table below shows examples of typical alarm conditions.

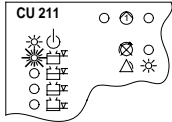

Wrong phase sequence (only three-phase variants):

- The **red** indicator light for wrong phase sequence is on.
  - The common alarm is active. The **red** indicator light is on.
  - Electricity supply switched on. The **green** indicator light is on.
- The pump *cannot* be started in this condition. Interchange two phases in the CEE plug.

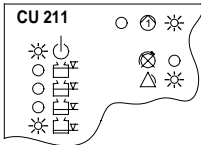

The level sensor is dirty or defective:

- The **red** indicator light for wrong phase sequence is on.
  - The common alarm is active. The **red** indicator light is on.
- During pumping, various combinations of orange indicator lights may be on. After pumping, the fault is indicated as illustrated in the figure.

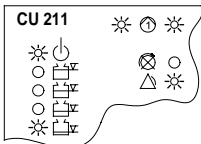

**Applies only if a motor-protective circuit breaker (accessory) has been installed.**

The motor-protective circuit breaker *has* cooled and has been reset manually after a cutout. The pump is running again:

- The pump is running. The **green** indicator light is **on**.
  - The **red** indicator light for pump fault is **on**.
  - The common alarm is active. The **red** indicator light is on.
  - The bottom **orange** indicator light is on.
  - Electricity supply switched on. The **green** indicator light is on.
- This alarm indication can be reset by resetting the alarm memory, see ON-OFF-AUTO selector switch, section 8.5.

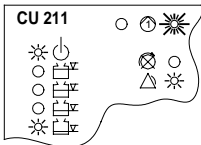

The motor thermal switch has cut out the pump. The motor has not yet cooled sufficiently:

- The **red** indicator light for pump fault is **flashing**.
- The common alarm is active. The **red** indicator light is on.
- The bottom **orange** indicator light is on.
- Electricity supply switched on. The **green** indicator light is on.

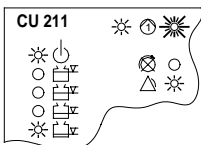

The pump *has* cooled after the thermal switch has caused a cutout. The pump is running again:

- The pump is running. The **green** indicator light is **on**.
  - The **red** indicator light for pump fault is **flashing**.
  - The common alarm is active. The **red** indicator light is on.
  - The bottom **orange** indicator light is on.
  - Electricity supply switched on. The **green** indicator light is on.
- This alarm indication can be reset by resetting the alarm memory, see ON-OFF-AUTO selector switch, section 8.5.

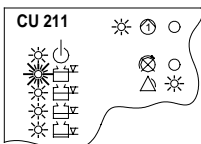

High-level alarm. The pump is running:

- The pump is running. The **green** indicator light is **on**.
- The common alarm is active. The **red** indicator light is on.
- The top **orange** indicator light is **flashing**.
- The other **orange** indicator lights are on.
- Electricity supply switched on. The **green** indicator light is on.

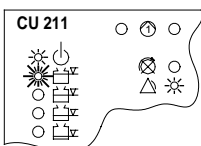

There *has been* a high-level situation and the liquid level in the collecting tank is now *lower than* the starting level of the pump:

- The common alarm is active. The **red** indicator light is on.
  - The top **orange** indicator light is **flashing**.
  - Electricity supply switched on. The **green** indicator light is on.
- This alarm indication can be reset by resetting the alarm memory, see ON-OFF-AUTO selector switch, section 8.5.

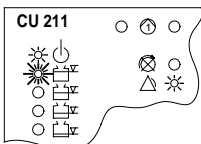

The level sensor is dirty or defective or the quantity of liquid at the inlet is too big:

- The common alarm is active. The **red** indicator light is on.
  - Electricity supply switched on. The **green** indicator light is on.
- This alarm indication can be reset by resetting the alarm memory, see ON-OFF-AUTO selector switch, section 8.5.

## 9. LCD 110 controller

### 9.1 Control panel

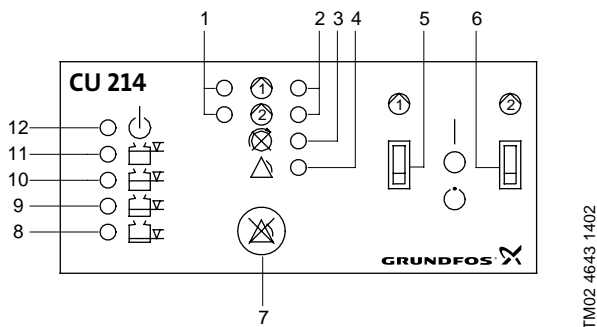

Fig. 23 Control panel, CU 214 module

TM02 4643 1402

Pos.	Description
1	Green indicator light for pumps 1 and 2, indicating starting delay (flashing) and pump operation (permanently on).
2	Red indicator light for pumps 1 and 2, indicating pump fault, flashing or permanently on, see section 9.7.
3	Red indicator light, indicating wrong phase sequence.
4	Red indicator light, indicating common alarm.
5	ON-OFF-AUTO selector switch for pump 1, three positions, see section 9.5.
6	ON-OFF-AUTO selector switch for pump 2, three positions, see section 9.5.
7	Reset button, push-button for manual resetting of alarm signals to <i>external</i> alarm devices and the built-in buzzer, see section 9.5.
8	Orange indicator light, which is activated by the level sensor for common stop.
9	Orange indicator light, which is activated by the level sensor for start of the first pump.
10	Orange indicator light, which is activated by the level sensor for start of the next pump.
11	Orange indicator light, which is activated by the level sensor for high-level alarm. In case of high-level alarm, the indicator light is flashing.
12	Green indicator light, indicating that the electricity supply has been switched on.

### 9.2 Application

The LCD 110 enables:

- control of two pumps based on level signals from the level sensor
- automatic pump changeover (even distribution of operating hours on both pumps)
- selection of automatic test run during long periods of inactivity (every 24 hours)
- battery back-up in case of mains supply failure (accessory for certain variants)
- starting delay within the range from 0 to 255 sec. (random)
- selection of automatic alarm resetting
- selection of automatic restarting
- setting of stop delays matching the current operating conditions
- indication of liquid level
- alarm indication in case of:
  - inadmissibly high liquid level
  - overload (via motor-protective circuit breaker)
  - overtemperature (via thermal switch in motor)
  - wrong phase sequence.

As standard, the LCD 110 has one alarm output for common alarm and one alarm output for separate high-level alarm. Furthermore, the controller incorporates a buzzer.

### 9.3 DIP switch

The CU 214 module has a 10-pole DIP switch positioned in the bottom right corner, see fig. 24.

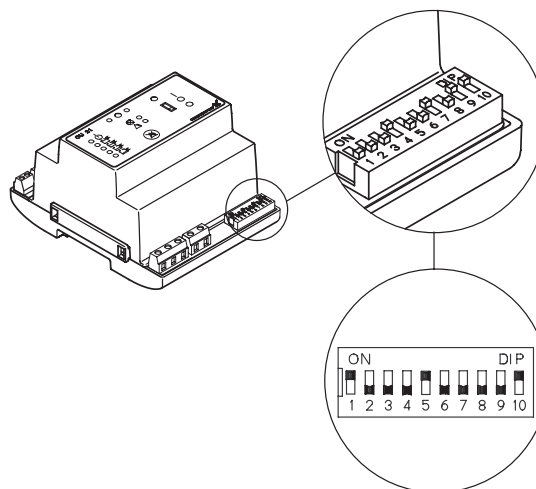

Fig. 24 CU 214 module with DIP switch

TM03 3650 0606

#### 9.3.1 Factory-setting of DIP switch

The DIP switch is factory-set, as shown in fig. 25.

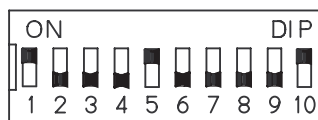

Fig. 25 Factory setting of DIP switch

TM03 3649 0606

Factory-set operation has

- no automatic test run
- 15 sec. after-flow
- manual resetting of alarm
- automatic restarting.

#### 9.3.2 DIP switch setting

**Note:** The DIP switch must not be set to other switch combinations than those described in this section.

**Note:** During setting, the controller must *always* be off circuit for at least 1 minute to ensure the correct configuration during start-up after change of the DIP switch setting.

The DIP switch setting offers the following possibilities:

- selection of starting delay and automatic test run (switch 4)
- setting of stop delay (switches 5, 6 and 7)
- selection of automatic alarm resetting (switch 9)
- selection of automatic restarting (switch 10).

Each individual switch (1 to 10) of the DIP switch can be set to position OFF or ON.

Set the switches 1 to 10 as follows:

- Switches 1, 2 and 3, application type:

When the DIP switch setting is changed, the controller must be switched off for at least 1 minute!



This setting determines the application type.

- Switch 4, starting delay and automatic test run (only in the case of battery back-up):

When the DIP switch setting is changed, the controller must be switched off for at least 1 minute!



At this setting, the start-up is delayed within the range from 0 to 255 sec. (random) after the electricity supply has been switched on, *when* the liquid level is sufficiently high. Automatic test run every 24 hours.



After the electricity has been switched on, the pump will start immediately *when* the liquid level is sufficiently high. No automatic test run.

- Switches 5, 6 and 7, stop delay:

When the DIP switch setting is changed, the controller must be switched off for at least 1 minute!

The **stop delay** is the time from the stop signal is given until the pumps are stopped.

It must be ensured that the pumps are not running dry.

0 sec.



60 sec.



15 sec.



90 sec.



30 sec.



120 sec.



45 sec.



180 sec.



- Switch 8:

When the DIP switch setting is changed, the controller must be switched off for at least 1 minute!



Switch 8 has no function in connection with the application, but this setting *must* be maintained!

- Switch 9, automatic alarm resetting:

When the DIP switch setting is changed, the controller must be switched off for at least 1 minute!



This setting ensures automatic resetting of alarm signals to external alarm devices and the built-in buzzer. However, an alarm signal will only be reset if the cause of the fault no longer exists.



At this setting, the alarm signal must be reset manually by means of the reset button (the reset button is described in 9.5 *Reset button and ON-OFF-AUTO selector switch*).

- Switch 10, automatic restarting:

When the DIP switch setting is changed, the controller must be switched off for at least 1 minute!



This setting enables automatic restarting after the motor thermal switch has cut out the pump. Restarting will not be carried out until the motor has cooled to normal temperature.



At this setting, the pumps must be restarted manually after the motor thermal switch has cut out the pump. To restart the pump, push the ON-OFF-AUTO selector switch into position OFF for a short period (the ON-OFF-AUTO selector switch is described in 9.5 *Reset button and ON-OFF-AUTO selector switch*).

### 9.4 Battery back-up functions

The backup battery is available as an accessory.

If a back-up battery for the CU 214 module is installed, the following functions will be carried out if the normal electricity supply to the LCD 110 *fails* (see also the illustrations below):

- The common alarm is active, the **red** indicator light is on – *cannot* be reset!
- If the *external* alarm device for common alarm is supplied from an external power source, this device will be active – *cannot* be reset by means of the reset button!
- The built-in buzzer is activated – can be reset by means of the reset button!
- If the liquid level rises above the level for high-level alarm, the top **orange** indicator light will be **flashing** and the second **orange** indicator light from the top will be permanently on.
- If the starting delay function and automatic test run were selected (switch 4 of the DIP switch), the start-up will be delayed after the electricity supply has been switched on when the liquid level is sufficiently high, see 9.3.2 *DIP switch setting*.

The table below shows the situations which may occur if the normal electricity supply to the LCD 110 *fails* and a back-up battery is connected:

○ = the indicator light is off.

⊗ = the indicator light is on.

⊛ = the indicator light is flashing.

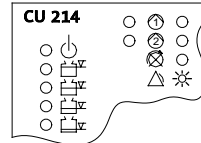

Mains supply failure:

- The common alarm is active. The **red** indicator light is on.
- The green indicator light (electricity supply switched on) is *off*.

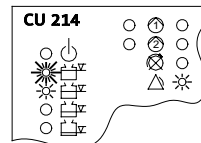

Mains supply failure *and* high-level alarm:

- The common alarm is active. The **red** indicator light is on.
- The top **orange** indicator light is **flashing**.
- The second **orange** indicator light from the top is on.
- The green indicator light (electricity supply switched on) is *off*.

## 9.5 Reset button and ON-OFF-AUTO selector switch

GB

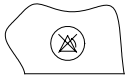

The **reset button** is a push-button for manual resetting of alarm signals to *external* alarm devices and the built-in buzzer (i.e. *not* for resetting of the alarm memory as this is reset by means of the ON-OFF-AUTO selector switch, see position OFF (○)).

Even if the fault condition still exists, the *external* alarm devices and the built-in buzzer will be reset when the reset button is pressed.

The **ON-OFF-AUTO selector switch** for each pump has three different positions:

**ON (|)**, top position:

- The pump will start when the selector switch is pushed into this position (unless the motor-protective circuit breaker has cut out the pump!).
- If the thermal switch of the motor registers overtemperature, the pump will be switched off.

**OFF (○)**, middle position:

- The pump *cannot* start when the selector switch has been set to this position.
- The alarm memory is reset by pushing the selector switch into position OFF (○). The alarm memory is the light indication of a fault condition which has disappeared. If a fault condition still exists when the selector switch is pushed into position ON (|) or AUTO (○), the alarm indication will be repeated immediately.

**AUTO (○)**, bottom position:

- The pump is controlled by the input signals from the level sensor and the pump according to the selected DIP switch setting.
- Alarm signals will automatically be reset. Switch 9 of the DIP switch can, however, be set to manual resetting, which is carried out by means of the reset button, see 9.3.2 *DIP switch setting*.
- The pump will restart automatically when a given fault condition disappears. However, this is dependent on the setting of switch 10 of the DIP switch, see 9.3.2 *DIP switch setting*.
- When the pump starts automatically after a fault condition which has disappeared, the indicator light will continue to show the fault condition (alarm memory) and the indication can only be removed by resetting the alarm memory, see position OFF (○).

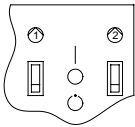

## 9.6 Normal operating conditions

The table below shows examples of typical alarm conditions.

Pumps 1 and 2 operate alternately. The examples show pump 2 as the first starting pump.

○ = the indicator light is off.

✱ = the indicator light is on.

✱✱ = the indicator light is flashing.

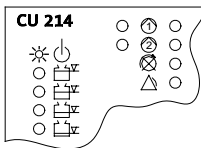

The liquid level in the collecting tank is *lower* than the stop level of the pumps (a stop delay has been set, see section 9.3.2):

- Electricity supply switched on. The **green** indicator light is on.

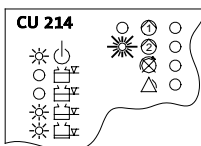

The liquid level in the collecting tank is *higher* than the starting level of the first pump:

- Starting delay of the pump. The **green** indicator light is **flashing**.
- The two bottom **orange** indicator lights are on.
- Electricity supply switched on. The **green** indicator light is on.

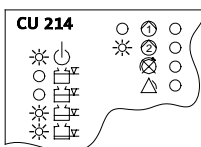

The liquid level in the collecting tank is *higher than* the starting level of the first pump:

- The pump is running. The **green** indicator light is **on**.
- The two bottom **orange** indicator lights are on.
- Electricity supply switched on. The **green** indicator light is on.

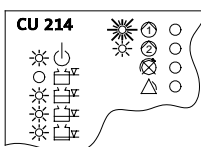

The liquid level in the collecting tank is *higher* than the starting level of the second pump:

- Starting delay of the pump. The **green** indicator light is **flashing**.
- The first pump is running. The **green** indicator light is **on**.
- The three bottom **orange** indicator lights are on.
- Electricity supply switched on. The **green** indicator light is on.

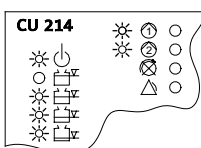

The liquid level in the collecting tank is *higher* than the starting level of the second pump:

- The pumps are running. The two **green** indicator lights are **on**.
- The three bottom **orange** indicator lights are on.
- Electricity supply switched on. The **green** indicator light is on.

## 9.7 Alarm conditions

**Common alarm** activates:

Red indicator light, built-in buzzer (only certain variants) and *external* alarm device for common alarm.

**High-level alarm** activates:

Common alarm (see above), *external* alarm device for high-level alarm, the top orange indicator light (**flashing**) and the other orange indicator lights (permanently on).

The table below shows examples of typical alarm conditions.

Pumps 1 and 2 operate alternately. The examples show pump 2 as the first starting pump.

○ = the indicator light is off.

⊗ = the indicator light is on.

⊗\* = the indicator light is flashing.

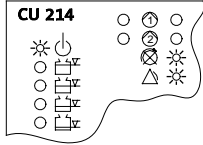

Wrong phase sequence (only three-phase versions):

- The **red** indicator light for wrong phase sequence is **on**.
- The common alarm is active. The **red** indicator light is on.
- Electricity supply switched on. The **green** indicator light is on.

The pumps *cannot* be started in this condition. The phases (L1, L2, L3) must first be connected in the correct order.

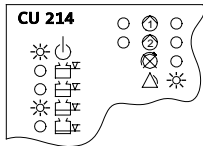

Dirty or defective level sensor. The liquid level in the collecting tank is *lower* than the stop level of the pumps:

- The common alarm is active. The **red** indicator light is on.
- The second **orange** indicator light from the bottom is on. The corresponding level sensor is dirty or defective.
- Electricity supply switched on. The **green** indicator light is on.

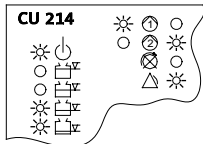

The motor-protective circuit breaker has cut out the first pump and has not yet cooled sufficiently:

- The **red** indicator light for pump fault is **on**.
- The other pump is running. The **green** indicator light is on.
- The common alarm is active. The **red** indicator light is on.
- The two bottom **orange** indicator lights are on.
- Electricity supply switched on. The **green** indicator light is on.

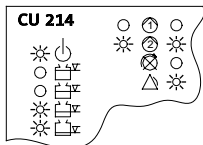

The motor-protective circuit breaker *has* cooled and has been reset manually after a cutout of the first pump. The pump is running again:

- The pump is running. The **green** indicator light is **on**.
- The **red** indicator light for pump fault is **on**.
- The common alarm is active. The **red** indicator light is on.
- The two bottom **orange** indicator lights are on.
- Electricity supply switched on. The **green** indicator light is on.

This alarm indication can be reset by resetting the alarm memory, see ON-OFF-AUTO selector switch, section 9.5.

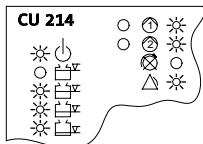

The motor-protective circuit breakers have cut out the pumps and have not yet cooled sufficiently:

- The two **red** indicator lights for pump fault are **on**.
- The common alarm is active. The **red** indicator light is on.
- The three bottom **orange** indicator lights are on.
- Electricity supply switched on. The **green** indicator light is on.

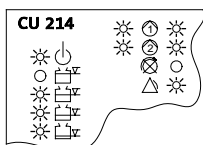

The motor-protective circuit breakers *have* cooled and have been reset manually after cutouts. The pumps are running again:

- The pumps are running. The two **green** indicator lights are **on**.
- The two **red** indicator lights for pump fault are **on**.
- The common alarm is active. The **red** indicator light is on.
- The three bottom **orange** indicator lights are on.
- Electricity supply switched on. The **green** indicator light is on.

This alarm indication can be reset by resetting the alarm memory, see ON-OFF-AUTO selector switch, section 9.5.

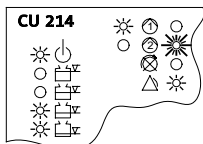

The motor thermal switch has cut out the first pump. The motor has not yet cooled sufficiently:

- The **red** indicator light for pump fault is **flashing**.
- The other pump is running. The **green** indicator light is **on**.
- The common alarm is active. The **red** indicator light is on.
- The two bottom **orange** indicator lights are on.
- Electricity supply switched on. The **green** indicator light is on.

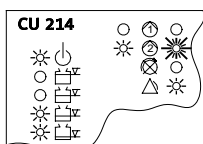

The first pump *has* cooled after the motor thermal switch has caused a cutout. The pump is running again:

- The pump is running. The **green** indicator light is **on**.
- The **red** indicator light for pump fault is **flashing**.
- The common alarm is active. The **red** indicator light is on.
- The two bottom **orange** indicator lights are on.
- Electricity supply switched on. The **green** indicator light is on.

This alarm indication can be reset by resetting the alarm memory, see ON-OFF-AUTO selector switch, section 9.5.

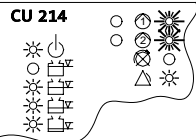

The motor thermal switches have cut out the pumps. The motors have not yet cooled sufficiently:

- The two **red** indicator lights for pump fault are **flashing**.
- The common alarm is active. The **red** indicator light is on.
- The three bottom **orange** indicator lights are on.
- Electricity supply switched on. The **green** indicator light is on.

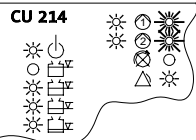

The pumps *have* cooled after the motor thermal switches have caused cutouts. The pumps are running again:

- The pumps are running. The two **green** indicator lights are **on**.
  - The two **red** indicator lights for pump fault are **flashing**.
  - The common alarm is active. The **red** indicator light is on.
  - The three bottom **orange** indicator lights are on.
  - Electricity supply switched on. The **green** indicator light is on.
- This alarm indication can be reset by resetting the alarm memory, see ON-OFF-AUTO selector switch, section 9.5.

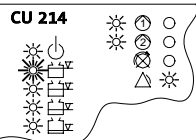

High-level alarm. The pumps are running:

- The top **orange** indicator light is **flashing**.
- The other **orange** indicator lights are on.
- The pumps are running. The two **green** indicator lights are **on**.
- The common alarm is active. The **red** indicator light is on.
- Electricity supply switched on. The **green** indicator light is on.

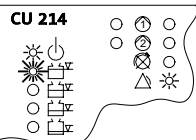

There *has been* a high-level situation, and the liquid level in the collecting tank is now *lower* than the stop level of the pumps.

- The top **orange** indicator light is **flashing**.
  - The common alarm is active. The **red** indicator light is on.
  - Electricity supply switched on. The **green** indicator light is on.
- This alarm indication can be reset by resetting the alarm memory, see ON-OFF-AUTO selector switch, section 9.5.

## 10. Maintenance and service

With normal usage, the MSS and MLD Multilift lifting stations require a minimum of maintenance.



Before carrying out maintenance and service on lifting stations used for pumping liquids which might be hazardous to health, make sure that the lifting station has been thoroughly flushed with clean water and that the discharge pipe has been drained. Rinse the parts in water after dismantling. Make sure that the isolating valves have been closed. The work must be carried out in accordance with local regulations.

Before making any connections in the LC 109 or LCD 110 or work on lifting stations, etc., it must be ensured that the electricity supply has been switched off and that it cannot be accidentally switched on.

Pumps in normal operation should be checked at least once a year. Local regulations must be observed.

These periodical checks of the lifting station should be carried out by authorized personnel and must among other things comprise electrical and mechanical maintenance. The following points should be checked:

- **Power consumption**

See nameplate.

- **Cable entry**

Make sure that the cable entry is watertight and that the cables are not bent sharply and/or pinched.

- **Pump parts**

Make a test run with clean water. In case of noise, vibration and abnormal running, contact Grundfos.

- **Ball bearings**

Check the shaft for noisy or heavy operation. Replace defective ball bearings.

A general overhaul of the pump is usually required in case of defective ball bearings or poor motor function. This work must be carried out by the manufacturer or an authorized service workshop.

### Cleaning the non-return valve (if required)

Proceed as follows:

1. Close the isolating valve in the discharge pipe and in the inlet pipe (if fitted) or drain the discharge pipe by tightening the drain screw on the side of the non-return valve, see 7. *Start-up*.
2. Clean the non-return valve via the cleaning cover on the side of the discharge pipe. If cleaning of the attachment of the flap is required, it might be necessary to remove the valve casing from the bottom part of the discharge pipe.

### 10.1 Electrical maintenance

- Check the gaskets of the LC 109 and LCD 110 cabinet front and those of the cable entries.
- Check the cable entries.
- Check the controller functions.
- Check and clean the level sensor. Check its functions, for instance in a bucket of water. See 10.2 *Cleaning the level sensor*.
- If the LC 109 or LCD 110 has been installed in a particularly aggressive environment, it is advisable to check the contacts of the motor-protective circuit breaker, if installed, in order to identify possible chemical attack resulting in corrosion. In typical installations, the contacts of the motor-protective circuit breaker contacts will work for several years and do not require any inspection.

**Note:** The above list is *not* complete. The LC 109 or LCD 110 may be installed in environments which require thorough and regular maintenance.

**Note:** Handle the sensor with care.

### 10.2 Cleaning the level sensor

1. Push the ON-OFF-AUTO selector switch into position OFF (○), see section 8.5.
2. Loosen the cover with level sensor by turning the union nut counter-clockwise.
3. Lift the sensor carefully out of the tank. Do not lift it by means of the cable.  
**Note:** The cover must always point upwards.
4. Check for possible deposits on or in the sensor tube and whether the vent hole on the side of the sensor tube is clean.
5. Scrape off any deposits. If necessary, rinse the sensor with clean water at low pressure, but do not flush the sensor tube.
6. Check the sensor by lowering it slowly into a bucket of water or similar. For MLD at least 600 mm deep.

**Note:** The controller must be under voltage, but the motor must be disconnected.

7. Check that the orange indicator lights for indication of liquid level illuminate in the order 1, 2, 3 and 4. When the orange indicator light 4 illuminates, the buzzer and the alarm signal relay are activated.

See 6.8.1 *Control panel* and 6.6 *Tank level above floor*.

8. When the indicator lights illuminate in the correct order, the sensor operates correctly and can be fitted again.

If the discharge pipe needs to be drained, see 7. *Start-up*.

### 10.3 Mechanical maintenance

- Check for possible deposits and/or sludge build-up in the collecting tank.
- Check for possible blockage on the inlet side of the lifting station. A blockage will typically be a large solid object.
- Check the gaskets of connections to the stationary system (at valves, etc.).
- Check the tank for cracks and deformations. These may occur in case of faulty assembly and therefore excessive stress on the tank.

**Note:** The above list is *not* complete. The lifting station may be installed in environments which require thorough and regular maintenance.

### 10.4 Contaminated lifting station or components



If a Multilift lifting station has been used for a liquid which is injurious to health or toxic, it will be classified as contaminated.

If Grundfos is requested to service the lifting station, Grundfos must be contacted with details about the pumped liquid, etc. *before* the lifting station is returned for service. Otherwise Grundfos can refuse to accept the lifting station for service.

Lifting stations which have been in contact with the pumped liquid must be thoroughly cleaned before they are returned to Grundfos. Possible costs of returning the lifting station are paid by the customer.

However, any application for service (no matter to whom it may be made) must include details about the pumped liquid if the lifting station has been used for liquids which are injurious to health or toxic.

## 11. Fault finding chart

Before carrying out any work on lifting stations used for pumping liquids which might be hazardous to health, make sure that the lifting station has been thoroughly flushed with clean water and that the discharge pipe has been drained. Rinse the parts in water after dismantling. Make sure that the isolating valves have been closed. The work must be carried out in accordance with local regulations.

Before making any connections in the LC 109 or LCD 110 or work on lifting stations, etc., it must be ensured that the electricity supply has been switched off and that it cannot be accidentally switched on.



GB

Fault	Cause	Remedy
1. The pump does not run.	a) No electricity supply. <b>Without battery back-up:</b> None of the indicator lights are on. <b>With battery back-up</b> (accessory): See section 8.4.	Switch on the electricity supply.
	b) The ON-OFF-AUTO selector switch is in position OFF (○), see section 8.5.	Push the ON-OFF-AUTO selector switch into position ON (  ) or AUTO (○).
	c) Connection not in accordance with these installation and operating instructions.	Connect the lifting station correctly, see 6.11 <i>Wiring diagram</i> .
	d) Control circuit fuses are blown.	Check and eliminate the cause. Replace the control circuit fuses (see pos. 6, fig. 12 or 14).
	e) The motor-protective circuit breaker has cut out the pump (only relevant if a motor-protective circuit breaker has been installed). The red indicator light for pump fault is permanently on, see section 8.7.	Check the pump and tank as well as the setting of the motor-protective circuit breaker.
	f) The thermal switch in the motor has cut out the pump. The red indicator light for pump fault is flashing, see section 8.7.	Allow the pump to cool. After cooling, the pump will restart automatically unless the LC 109 or LCD 110 has been set to manual restarting, see section 7.2. If so, the ON-OFF-AUTO selector switch must be pushed into position OFF (○) for a short period. If the cutout is due to impurities in tank or system, send for a sludge exhauster. If the level sensor is dirty, lift out the cover with sensor and clean the sensor.
	g) The control circuit for the motor-protective circuit breaker has been broken or fails (only relevant if a motor-protective circuit breaker has been installed). The green indicator light indicating pump operation is permanently on, see section 6.8.1.	Check control circuit.
	h) Motor or supply cable is defective.	Check motor and cable.
	i) Level sensor is dirty or defective.	Check cables. Clean or replace the level sensor.
	j) Pump is blocked or defective.	Clean, repair or replace the pump.
	k) Liquid level in collecting tank is too low.	Supply liquid (clean water) to the tank.
	l) Controller is defective.	Check the controller and replace possible defective components.
	m) The new DIP switch setting does not work correctly.	Switch off the electricity supply to the controller for 1 minute and switch it on again (normal procedure), see section 7.2.
2. The pump is starting/stopping frequently or runs constantly.	a) Level sensor is dirty or defective.	Check cables. Clean or replace the level sensor.
	b) Contactor in controller is defective.	Replace the contactor.
	c) Controller is defective.	Check the controller and replace possible defective components.
	d) Non-return valve is blocked or leaking.	Clean the non-return valve, see 10. <i>Maintenance and service</i> .

### 11.1 Fuses

The LC 109 and LCD 110 controllers are provided with a fine-wire fuse for protection of the electronics. If the fuse is defective, replace it by a fuse of the same type. A spare fuse is positioned inside the controller.

## 12. Technical data

### Supply voltage

- 1 x 230 V -10/+6%, 50 Hz, PE.
- 3 x 230 V -10/+6%, 50 Hz, PE.
- 3 x 400 V -10/+6%/N, 50 Hz, PE.

See nameplate.

### Supply system earthing

For TN systems and TT systems.

### Rated insulation voltage, $U_i$

4 kV.

### Rated impulse withstand voltage, $U_{imp}$

4 kV.

### Back-up fuse (as a guide)

Type	[V]	Back-up fuse
MSS.12.1.4	230	16 A
MSS.12.3.4	230/400	16 A/16 A
MLD.15.1.4	230	25 A
MLD.15.3.4	230/400	16 A/16 A
MLD.22.3.4	230/400	16 A/16 A
MLD.24.3.4	230/400	35 A/25 A
MLD.32.3.4	230/400	35 A/25 A

### Output voltage for pump

- 1 x 230 V, 50 Hz.
- 3 x 230 V, 50 Hz.
- 3 x 400 V, 50 Hz.

Depending on the supply voltage.

### Outputs for alarm devices

Max. 400 VAC / max. 2 A / min. 10 mA / AC1.

### Controller power consumption

8-12 W.

### Control circuit fuse

Fine-wire fuse: 250 mA / F / 32 mm x ø6 mm.

### Ambient temperature

- During operation: 0°C to +40°C.
- In stock: -30°C to +50°C.

The controller must not be exposed to direct sunlight.

### Liquid temperature

- 0°C to +40°C.
- For short periods up to +60°C (maximum 5 minutes per hour).

### pH-value

4 to 10.

### Maximum density of liquid

1100 kg/m<sup>3</sup>.

### Operating mode

Max. 20 starts per hour.

Note that the pumps are only designed for intermittent operation.

Type	Operating mode
MSS.12.1.4	S3-13% 3 min.
MSS.12.3.4	S3-40% 1 min.
MLD.15.1.4	S3-13% 3 min.
MLD.15.3.4	S3-40% 1 min.
MLD.22.3.4	S3-40% 1 min.
MLD.24.3.2	S3-20% 1 min.
MLD.32.3.2	S3-20% 1 min.

## Performance (one pump running)

Type	$Q_{max.}$	$H_{min.}$	$H_{max.}$
	[m <sup>3</sup> ]	[m]	[m]
MSS.12.1.4	39.6	5.0	8.5
MSS.12.3.4	39.6	3.4	7.7
MLD.15.1.4	54.0	3.5	9.1
MLD.15.3.4	57.6	3.3	9.0
MLD.22.3.4	45.0	6.2	10.2
MLD.24.3.2	29.9	7.9	15.8
MLD.32.3.2	25.2	12.4	19.5

### Motor protection

Thermal switch incorporated in motor windings.

### Enclosure class

- Motor: IP 68.
- Controller: IP 55.

### Sound pressure level

The sound pressure level of the pump is lower than the limiting values stated in the EC Council Directive 98/37/EC relating to machinery.

### EMC (electromagnetic compatibility)

According to EN 61000-6-2 and EN 61000-6-3.

### Dimensions

See dimensional sketches at the end of these instructions.

### Controller cabinet

- External dimensions:  
Height = 350 mm, width = 250 mm, depth = 136 mm.
- Material: Technopolymer and polycarbonate.
- Weight: Approx. 3 kg, see nameplate.

## 12.1 Pump curve

The curve is only intended as a guide and must *not* be used as a guarantee curve. Tolerances are according to ISO 9906 Annex A.

GB

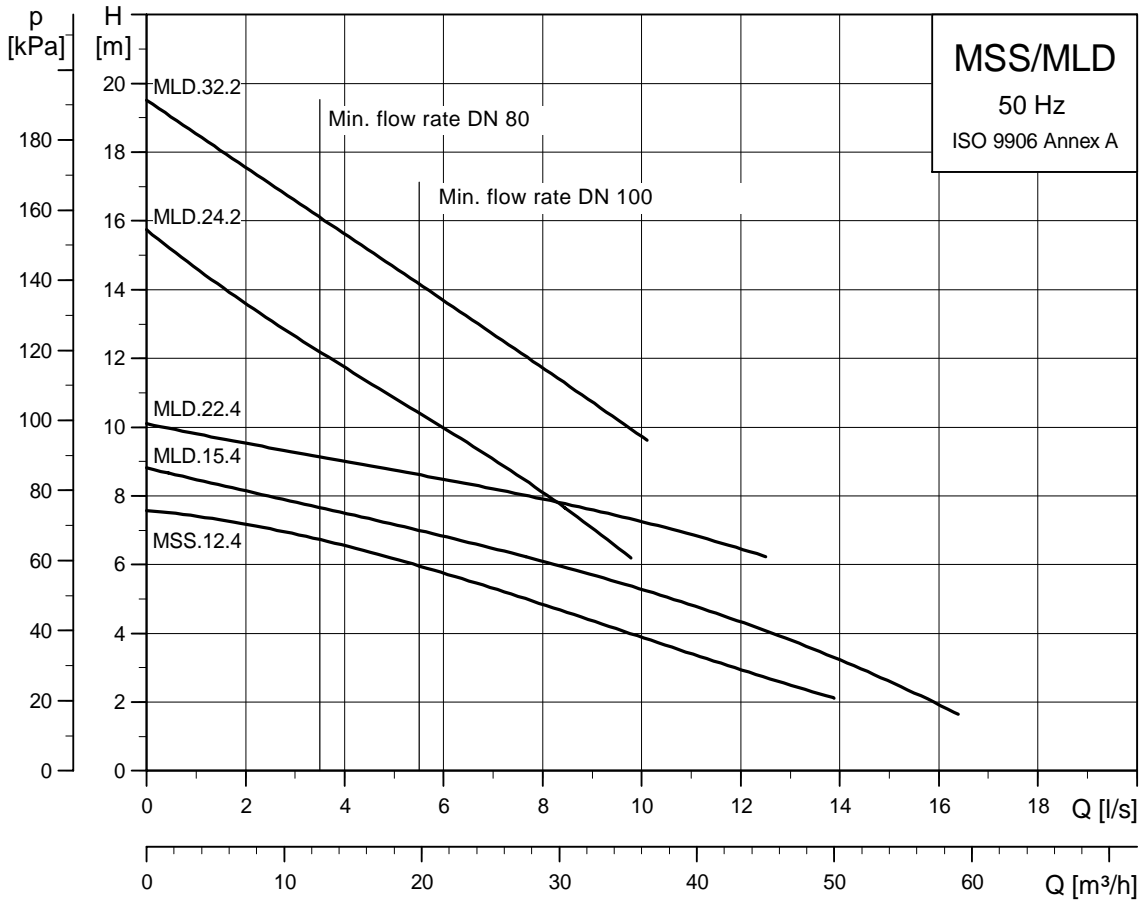

Fig. 26 Pump curves

## 13. Disposal

This product or parts of it must be disposed of in an environmentally sound way:

1. Use the public or private waste collection service.
2. If this is not possible, contact the nearest Grundfos company or service workshop.

TM03 2587 4605

Subject to alterations.

**Denmark**

GRUNDFOS DK A/S  
Martin Bachs Vej 3  
DK-8850 Bjerringbro  
Tlf.: +45-87 50 50 50  
Telefax: +45-87 50 51 51  
E-mail: info\_GDK@grundfos.com  
www.grundfos.com/DK

**Albania**

COALB sh.p.k.  
Rr.Dervish Hekali N.1  
AL-Tirana  
Phone: +355 42 22727  
Telefax: +355 42 22727

**Argentina**

Bombas GRUNDFOS de Argentina S.A.  
Ruta Panamericana km. 37.500 Lote 34A  
1619 - Garin  
Pcia. de Buenos Aires  
Phone: +54-3327 414 444  
Telefax: +54-3327 411 111

**Australia**

GRUNDFOS Pumps Pty. Ltd.  
P.O. Box 2040  
Regency Park  
South Australia 5942  
Phone: +61-8-8461-4611  
Telefax: +61-8-8340 0155

**Austria**

GRUNDFOS Pumpen Vertrieb Ges.m.b.H.  
Grundfosstraße 2  
A-5082 Grödig/Salzburg  
Tel.: +43-6246-883-0  
Telefax: +43-6246-883-30

**Belgium**

N.V. GRUNDFOS Bellux S.A.  
Boomssesteenweg 81-83  
B-2630 Aartselaar  
Tél.: +32-3-870 7300  
Télécopie: +32-3-870 7301

**Belorussia**

Представительство ГРУНДФОС в  
Минске  
220090 Минск ул.Олешева 14  
Телефон: (8632) 62-40-49  
Факс: (8632) 62-40-49

**Bosnia/Herzegovina**

GRUNDFOS Sarajevo  
Paromilinska br. 16,  
BiH-71000 Sarajevo  
Phone: +387 33 713290  
Telefax: +387 33 231795

**Brazil**

GRUNDFOS do Brasil Ltda.  
Rua Tomazina 106  
CEP 83325 - 040  
Pinhais - PR  
Phone: +55-41 668 3555  
Telefax: +55-41 668 3554

**Bulgaria**

GRUNDFOS Pumpen Vertrieb  
Representative Office - Bulgaria  
Bulgaria, 1421 Sofia  
Lozenetz District  
105-107 Arsenalski blvd.  
Phone: +359 2963 3820, 2963 5653  
Telefax: +359 2963 1305

**Canada**

GRUNDFOS Canada Inc.  
2941 Brighton Road  
Oakville, Ontario  
L6H 6C9  
Phone: +1-905 829 9533  
Telefax: +1-905 829 9512

**China**

GRUNDFOS Pumps (Shanghai) Co. Ltd.  
22 Floor, Xin Hua Lian Building  
755-775 Huai Hai Rd, (M)  
Shanghai 200020  
PRC  
Phone: +86-512-67 61 11 80  
Telefax: +86-512-67 61 81 67

**Croatia**

GRUNDFOS predstavništvo Zagreb  
Cebini 37, Buzin  
HR-10000 Zagreb  
Phone: +385 1 6595 400  
Telefax: +385 1 6595 499

**Czech Republic**

GRUNDFOS s.r.o.  
Čajkovského 21  
779 00 Olomouc  
Phone: +420-585-716 111  
Telefax: +420-585-438 906

**Estonia**

GRUNDFOS Pumps Eesti OÜ  
Peterburi tee 44  
11415 Tallinn  
Tel: + 372 606 1690  
Fax: + 372 606 1691

**Finland**

OY GRUNDFOS Pumput AB  
Mestarintie 11  
Piispankylä  
FIN-01730 Vantaa (Helsinki)  
Phone: +358-9 878 9150  
Telefax: +358-9 878 91550

**France**

Pompes GRUNDFOS Distribution S.A.  
Parc d'Activités de Chesnes  
57, rue de Malacombe  
F-38290 St. Quentin Fallavier (Lyon)  
Tél.: +33-4 74 82 15 15  
Télécopie: +33-4 74 94 10 51

**Germany**

GRUNDFOS GMBH  
Schlüterstr. 33  
40699 Erkrath  
Tel.: +49-(0) 211 929 69-0  
Telefax: +49-(0) 211 929 69-3799  
e-mail: infoservice@grundfos.de  
Service in Deutschland:  
e-mail: kundendienst@grundfos.de

**Greece**

GRUNDFOS Hellas A.E.B.E.  
20th km. Athinon-Markopoulou Av.  
P.O. Box 71  
GR-19002 Peania  
Phone: +0030-210-66 83 400  
Telefax: +0030-210-66 46 273

**Hong Kong**

GRUNDFOS Pumps (Hong Kong) Ltd.  
Unit 1, Ground floor  
Siu Wai Industrial Centre  
29-33 Wing Hong Street &  
68 King Lam Street, Cheung Sha Wan  
Kowloon  
Phone: +852-27861706/27861741  
Telefax: +852-27858664

**Hungary**

GRUNDFOS Hungária Kft.  
Park u. 8  
H-2045 Törökbalint,  
Phone: +36-23 511 110  
Telefax: +36-23 511 111

**India**

GRUNDFOS Pumps India Private Limited  
Flat A, Ground Floor  
61/62 Chamiers Aptmt  
Chamiers Road  
Chennai 600 028  
Phone: +91-44 432 3487  
Telefax: +91-44 432 3489

**Indonesia**

PT GRUNDFOS Pompa  
Jl. Rawa Sumur III, Blok III / CC-1  
Kawasan Industri, Pulogadung  
Jakarta 13930  
Phone: +62-21-460 6909  
Telefax: +62-21-460 6910/460 6901

**Ireland**

GRUNDFOS (Ireland) Ltd.  
Unit A, Merrywell Business Park  
Ballymount Road Lower  
Dublin 12  
Phone: +353-1-4089 800  
Telefax: +353-1-4089 830

**Italy**

GRUNDFOS Pompe Italia S.r.l.  
Via Gran Sasso 4  
I-20060 Truccazzano (Milano)  
Tel.: +39-02-95838112  
Telefax: +39-02-95309290/95838461

**Japan**

GRUNDFOS Pumps K.K.  
1-2-3, Shin Miyakoda  
Hamamatsu City  
Shizuoka pref. 431-21  
Phone: +81-53-428 4760  
Telefax: +81-53-484 1014

**Korea**

GRUNDFOS Pumps Korea Ltd.  
6th Floor, Aju Building 679-5  
Yeoksam-dong, Kangnam-ku, 135-916  
Seoul, Korea  
Phone: +82-2-5317 600  
Telefax: +82-2-5633 725

**Latvia**

SIA GRUNDFOS Pumps Latvia  
Deglava biznesa centrs  
Augusta Deglava ielā 60, LV-1035, Rīga,  
Tālr.: + 371 714 9640, 7 149 641  
Fakss: + 371 914 9646

**Lithuania**

GRUNDFOS Pumps UAB  
Smolensko g. 6  
LT-03201 Vilnius  
Tel: + 370 52 395 430  
Fax: + 370 52 395 431

**Macedonia**

MAKOTERM  
Dame Gruev Street 7  
MK-91000 Skopje  
Phone: +389 91 117733  
Telefax: +389 91 220100

**Malaysia**

GRUNDFOS Pumps Sdn. Bhd.  
7 Jalan Peguam U1/25  
Glenmarie Industrial Park  
40150 Shah Alam  
Selangor  
Phone: +60-3-5569 2922  
Telefax: +60-3-5569 2866

**Mexico**

Bombas GRUNDFOS de Mexico S.A. de  
C.V.  
Boulevard TLC No. 15  
Parque Industrial Stiva Aeropuerto  
Apodaca, N.L. 66600  
Mexico  
Phone: +52-81-8144 4000  
Telefax: +52-81-8144 4010

**Netherlands**

GRUNDFOS Nederland B.V.  
Postbus 104  
NL-1380 AC Weesp  
Tel.: +31-294-492 211  
Telefax: +31-294-492244/492299

**New Zealand**

GRUNDFOS Pumps NZ Ltd.  
17 Beatrice Tinsley Crescent  
North Harbour Industrial Estate  
Albany, Auckland  
Phone: +64-9-415 3240  
Telefax: +64-9-415 3250

**Norway**

GRUNDFOS Pumper A/S  
Strømsveien 344  
Postboks 235, Leirdal  
N-1011 Oslo  
Tlf.: +47-22 90 47 00  
Telefax: +47-22 32 21 50

**Poland**

GRUNDFOS Pompy Sp. z o.o.  
ul. Klonowa 23  
Baranowo k. Poznania  
PL-62-081 Przeźmierowo  
Phone: (+48-61) 650 13 00  
Telefax: (+48-61) 650 13 50

**Portugal**

Bombas GRUNDFOS Portugal, S.A.  
Rua Calvet de Magalhães, 241  
Apartado 1079  
P-2770-153 Paço de Arcos  
Tel.: +351-21-440 76 00  
Telefax: +351-21-440 76 90

**Republic of Moldova**

MOLDOCON S.R.L.  
Bd. Dacia 40/1  
MD-277062 Chishinau  
Phone: +373 2 542530  
Telefax: +373 2 542531

**Romania**

GRUNDFOS Pompe România SRL  
Bd. Biruintei, nr 103  
Pantelimon county Ilfov  
Phone: +40 21 200 4100  
Telefax: +40 21 200 4101  
E-mail: romania@grundfos.ro

**Russia**

ООО Грундфос  
Россия, 109544 Москва, Школьная 39  
Тел. (+7) 095 737 30 00, 564 88 00  
Факс (+7) 095 737 75 36, 564 88 11  
E-mail grundfos.moscow@grundfos.com

**Serbia and Montenegro**

GRUNDFOS Predstavništvo Beograd  
Dr. Milutina Ivkovića 2a/29  
YU-11000 Beograd  
Phone: +381 11 26 47 877, 11 26 47 496  
Telefax: +381 11 26 48 340

**Singapore**

GRUNDFOS (Singapore) Pte. Ltd.  
24 Tuas West Road  
Jurong Town  
Singapore 638381  
Phone: +65-6865 1222  
Telefax: +65-6861 8402

**Slovenia**

GRUNDFOS PUMPEN VERTRIEB  
Ges.m.b.H.,  
Podružnica Ljubljana  
Blatnica 1, SI-1236 Trzin  
Phone: +386 1 563 5338  
Telefax: +386 1 563 2098  
E-mail: slovenia@grundfos.si

**Spain**

Bombas GRUNDFOS España S.A.  
Camino de la Fuentevilla, s/n  
E-28110 Algete (Madrid)  
Tel.: +34-91-848 8800  
Telefax: +34-91-628 0465

**Sweden**

GRUNDFOS AB  
Lunnagårdsgatan 6  
431 90 Mölndal  
Tel.: +46-0771-32 23 00  
Telefax: +46-31 331 94 60

**Switzerland**

GRUNDFOS Pumpen AG  
Bruggacherstrasse 10  
CH-8117 Fällanden/ZH  
Tel.: +41-1-806 8111  
Telefax: +41-1-806 8115

**Taiwan**

GRUNDFOS Pumps (Taiwan) Ltd.  
7 Floor, 219 Min-Chuan Road  
Taichung, Taiwan, R.O.C.  
Phone: +886-4-2305 0868  
Telefax: +886-4-2305 0878

**Thailand**

GRUNDFOS (Thailand) Ltd.  
947/168 Moo 12, Bangna-Trad Rd., K.M.  
3,  
Bangna, Phrakonong  
Bangkok 10260  
Phone: +66-2-744 1785 ... 91  
Telefax: +66-2-744 1775 ... 6

**Turkey**

GRUNDFOS POMPA San. ve Tic. Ltd. Sti.  
Gebze Organize Sanayi Bölgesi  
İhsan dede Caddesi,  
2. yol 200. Sokak No. 204  
41490 Gebze/ Kocaeli  
Phone: +90 - 262-679 7979  
Telefax: +90 - 262-679 7905  
E-mail: satis@grundfos.com

**Ukraine**

ТОВ ГРУНДФОС Україна  
ул. Владимирская, 71, оф. 45  
г. Киев, 01033, Украина,  
Тел. +380 44 289 4050  
Факс +380 44 289 4139

**United Arab Emirates**

GRUNDFOS Gulf Distribution  
P.O. Box 16768  
Jebel Ali Free Zone  
Dubai  
Phone: +971-4- 8815 166  
Telefax: +971-4-8815 136

**United Kingdom**

GRUNDFOS Pumps Ltd.  
Grovebury Road  
Leighton Buzzard/Beds. LU7 8TL  
Phone: +44-1525-850000  
Telefax: +44-1525-850011

**U.S.A.**

GRUNDFOS Pumps Corporation  
17100 West 118th Terrace  
Olathe, Kansas 66061  
Phone: +1-913-227-3400  
Telefax: +1-913-227-3500

**Usbekistan**

Представительство ГРУНДФОС в  
Ташкенте  
700000 Ташкент ул.Усмана Носира 1-й  
тулик 5  
Телефон: (3712) 55-68-15  
Факс: (3712) 53-36-35

<b>96621350</b> 0406	<b>21</b>
Repl. 96621350 0306	